

# Videosys Broadcast

## ODU User Manual

Revision 1.0      10/05/2018

### **Videosys Broadcast Ltd**

Unit 1-2 Forest Farm Barn

Turners Hill Road

Turners Hill

West Sussex, RH10 4QH

Tel: +44 1293 541200

[www.videosys.tv](http://www.videosys.tv)

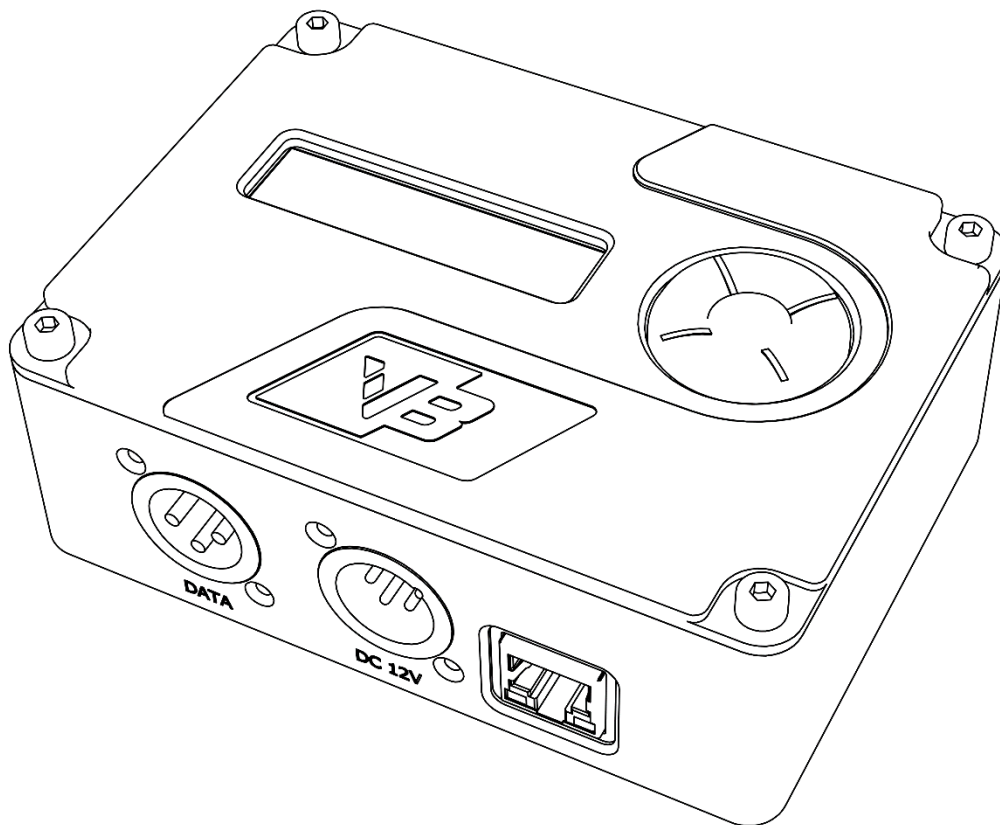

## Contents

Your Camera Control Outdoor Unit .....	3
Front Panel.....	3
Top Connectors.....	3
Bottom Connectors.....	3
Getting Started.....	4
Introduction .....	4
Principal of Operation .....	4
Connecting Components.....	5
Navigating Menus .....	5
Status Screens.....	5
Menu Structure .....	6
Web Interface.....	7
Accessing the Web Interface .....	7
Unit Updates.....	9
Specification.....	10
Physical Parameters .....	10
Electrical Parameters .....	10
Backwards Compatibility .....	11
Connector Wiring Diagrams .....	11
Data Input .....	11
Power Input Connector .....	11

# Your Camera Control Outdoor Unit

## Front Panel

1. Up Button
2. Right Button
3. Down Button
4. Left Button
5. Enter Button
6. OLED Display

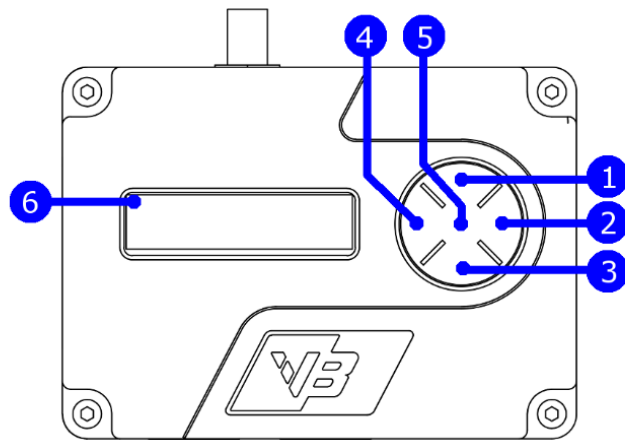

## Top Connectors

7. TNC transmit antenna connector

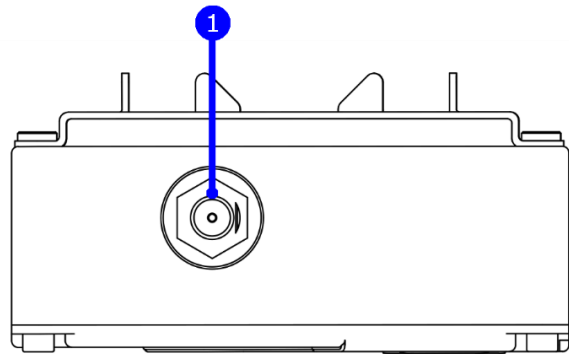

## Bottom Connectors

1. Data Input Connector (3 Pin XLR, Male)
2. Power Input Connector (4 Pin XLR, Male)
3. Ethernet Connector (RJ45)
4. RX signal indicator light.

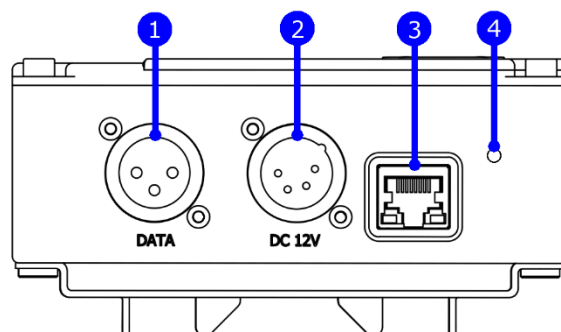

# Getting Started

Thank you for purchasing a Videosys ODU, we hope that you will find the necessary information within this manual and our specific quick setup guides, if however, you require additional support please don't hesitate to contact your local distributor.

## Introduction

The Videosys camera control system allows you to replace the cables between your Remote Control Panels, Camera Control Units and Cameras with a robust broadcast quality wireless link.

The Videosys camera control solution consists of three distinct components; an 'IDU' (In Door Unit), 'ODU' (Out Door Unit) and an 'RX' (Receiver). Multiples of these components can be used to best fit the operators requirements, for example multiple IDUs can be connected to allow for many camera control paths over one ODU. Multiple ODUs can be used to increase RF coverage, and each camera to be controlled requires an RX.

From this point on to avoid ambiguity and keep things concise, the terms IDU, ODU, RCP and RX will be used.

## Principal of Operation

The Videosys ODU is fundamentally a data transmitter, it accepts data via Ethernet, RS232 or RS485 and transmits this data over the air to be received by one or more camera control RX. The second generation ODU has the capability to intercept and interpret camera control data, which combined with IP networking features such as multicast, allow for a huge amount of flexibility with multi ODU set-ups.

The most basic uni-directional set up is shown in *Fig 1*. Where a single ODU is sending control data to be received by a single RX.

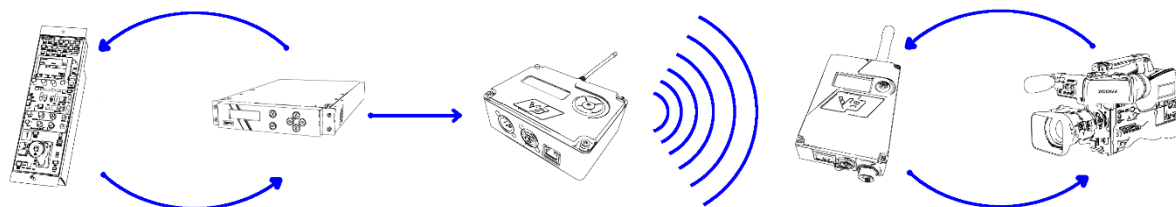

*Fig 1. A simple uni-directional camera control setup*

## Connecting Components

Your Camera control ODU requires three things, a source of power, a source of data and an antenna with which to transmit.

Power can be supplied either via the Power Input Connector, or via the RJ45 connector utilising Power over Ethernet. The ODU will automatically switch between these two inputs, and if both are connected the Power Input Connector will be preferred.

Data can be provided either via the Data Connector as RS232, RS485 or via Ethernet using the using the appropriate configuration on your IDU. The ODU can be configured to automatically select an active data source, selected between groups of sources or locked to only respond to a specific source.

RS485 control, when used with a Videosys IDU, will operate on up to 1500m cable lengths. Using Ethernet, cable lengths of up to 100m can be used per segment. It should be noted that many cheap and readily available range extending solutions exist for IP networks. RS232 connectivity is only rated for 15M and is provided to allow operators to use equipment such as off-the-shelf serial to fibre converters.

## Navigating Menus

The Up, Down, Left, Right and Enter buttons can be used to navigate through the menus. Menus are organised into lists, these can be scrolled through with the Up and Down buttons. To enter the selected submenu or option, press the Right button. Left will return you to previous menu. The centre-click Enter button is used to set or save options such as frequency or IP addresses.

Within a text edit screen, you can use the left and right buttons to select the character you are editing and the up and down buttons to change that character. To save and return press the Enter button, to discard and return use the Left button to scroll back to the first character and then press Left once more to return.

## Status Screens

The first screen that will be displayed to the user is the status screen (*Fig 2*), this is designed to give a quick overview of the units configuration and operating status.

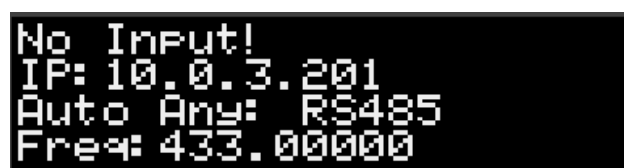

```
No Input!  
IP: 10.0.3.201  
Auto Any: RS485  
Freq: 433.00000
```

*Fig 2. The ODU status screen*

The first line of text shows the transmitting status, so long as the unit is receiving valid data it will transmit, this gives two potential messages 'No Input' or 'Transmitting'.

On the second line the IP address is displayed to help with quickly configuring an IP system.

Data input is displayed on the third line, if a range of inputs are selected this is also displayed along with the current selection, in this case the range is 'Auto Any' and the selection the device has made is 'RS485'. If a single input is selected rather than a range this screen will display 'Locked' and then the selected input.

The final line shows the transmit frequency.

## Menu Structure



Fig 3. ODU menu structure diagram

Pressing Enter will move the user from the status screen to the main menu, this main menu has the category groupings for the various settings and options, these are as follows;

Radio – Within this submenu there are pages that allow the user to view and set the radio transmit frequency and power. Due to the radios operation it can only transmit on frequencies that are a multiple of 6.25KHz, in the case that an invalid frequency is entered, the unit will select the nearest valid frequency.

System – Contains options such as data input modes (RS232, RS485, IP, Auto Serial Only and Auto Any), System Reset and System Info. System Info displays software version, unit serial number and Satel module serial number.

Network – set IP address, netmask, gateway and multicast options

## Web Interface

The ODU has a built-in webserver and serves a range of useful control pages, if you have a device with a web browser on the same network, you can use this interface to quickly change settings and perform updates.

### Accessing the Web Interface

To Access the Web interface, firstly power up your ODU and connect a PC or laptop up to the same IP network as your ODU. Find the IP address of your ODU (this can be found on the status page) and enter this into your browser, this will take you to the configuration web page.

Network Settings	
IP Address	192.168.1.241
IP Mask	255.255.255.0
IP Gateway	192.168.1.254

Save Settings

Fig 4. The ODUs Network Configuration Webpage

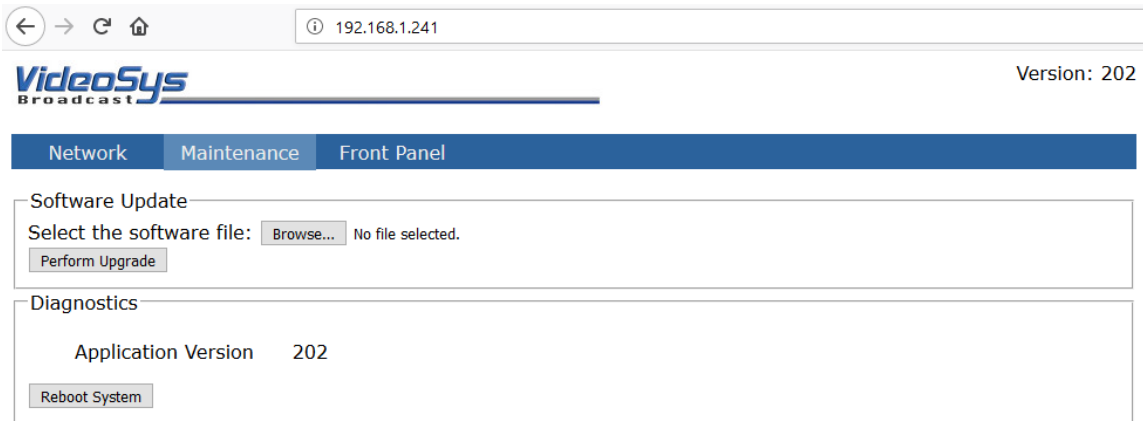

Fig 5. The ODUs Maintenance Webpage

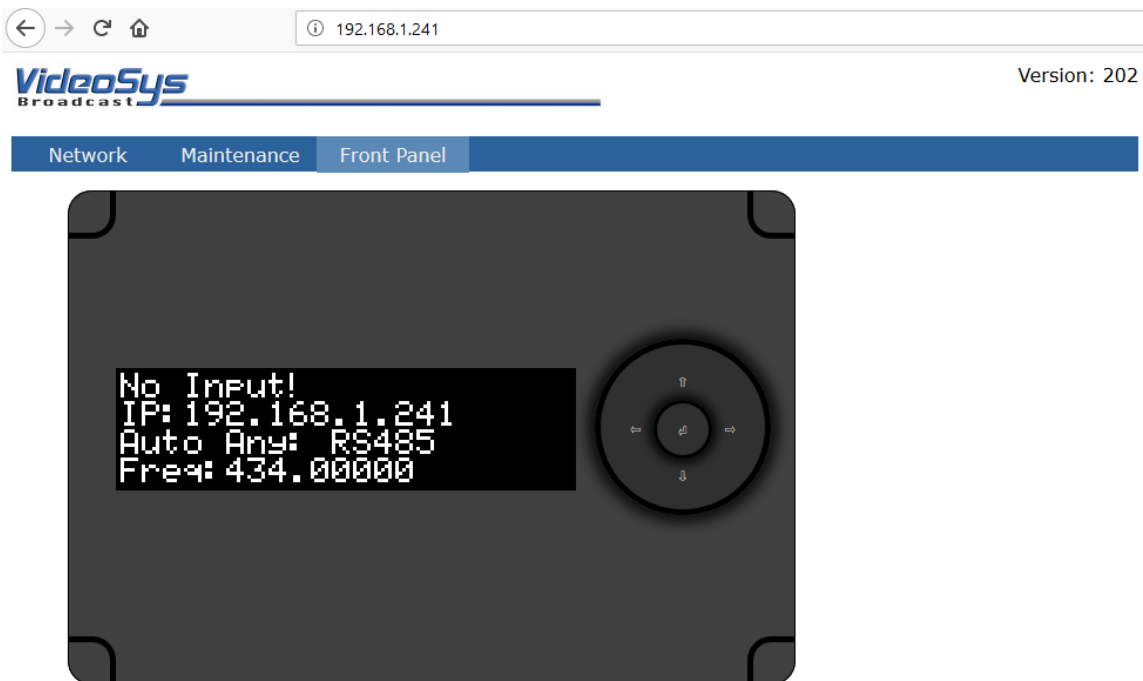

Fig 6. The ODUs Front Panel Webpage

Once you have loaded the webpage (see 'Accessing the Web Interface'), you should see the 'Network' Page (fig 4), from this page you can easily and quickly configure the unit as part of an IP network. There is also a 'Maintenance' page, giving device information and allowing for updates (these can be found on our website) and a 'Front Panel' page that mirrors the information presented on the ODUs front panel and allows all of the same functionality as the units physical front panel.

## Unit Updates

To update your ODU, firstly you will need to obtain a new firmware image, these are available on our website. Please check the release notes bundled with the firmware images carefully, they will explain precisely what changes have been made. The next step is to access the webpage (see 'Accessing the Web Interface'). On the 'Maintenance' page (*fig 5*). you will find a software update section, use this to select and upload the file. During the update you will notice that the ODU will inform you that it is restarting and then that it is updating. If you have any questions about which firmware image you should be using or require any additional support please your local distributor.

# Specification

## Physical Parameters

### Dimensions

**Width:** 125mm  
**Height:** 104mm  
**Depth:** 46mm  
(Without Mounting Bracket), 63mm  
(With Mounting Bracket)

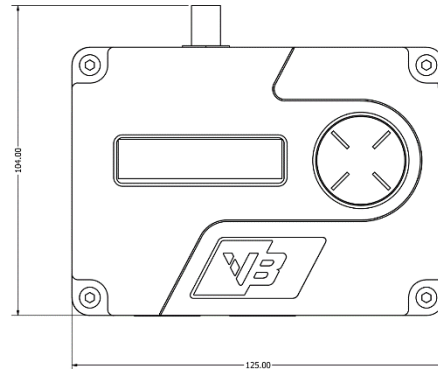
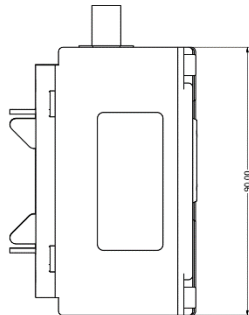

**Weight:** 510g  
(Excluding Brackets)

### Weather proofing:

Unrated – splash proof front/top

### Temperature

**Range:** 0-50 °C

**Sound Output:** None – Fanless

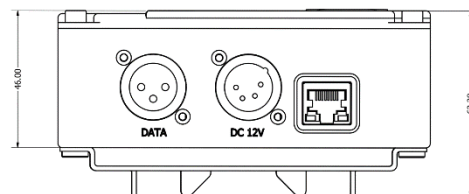

## Electrical Parameters

**Voltage Input:** 9-36V DC (4 pin XLR)  
36-57V IEEE802.3af PoE (RJ45)

**Power Requirement:** 6W typical at 1W transmit.  
3W typical Idle.

**Radio Output Power:** 100mW, 200mW, 500mW, 1000mW (Selectable)

**Radio Frequency:** 403 - 473 MHz (Selectable)

**Radio Bandwidth:** 12.5KHz

## Backwards Compatibility

We have multiple generations of hardware, which due to our commitment to backwards compatibility can, in the vast majority of cases, still be used to build a high-performance camera control system. If you are integrating new components into a previous generation system however, some of our latest features might not be available. Please check our software release notes for the version that you are running or contact our sales department for more information.

## Connector Wiring Diagrams

The following diagrams are from the point of view of the rear panel of the ODU facing the user.

### Data Input

3-Pin XLR, Female, *NEUTRIK NC3MAH*

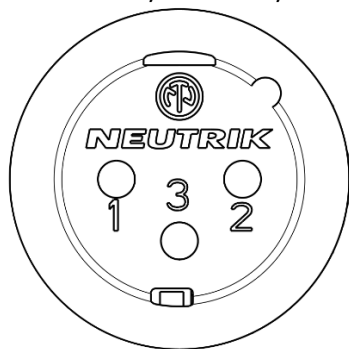

Pin 1: Ground

In RS232 Mode:

Pin 2: RS232 Rx

Pin 3: RS232 Tx

In RS484 Mode

Pin 2: RS485 Data -

Pin 3: RS485 Data +

### Power Input Connector

4-Pin XLR, Male, *NEUTRIK NC4MAH*

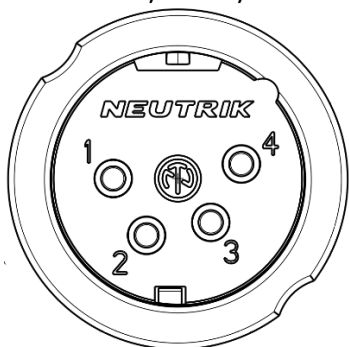

Pin 1: Ground

Pin 2: NC

Pin 3: NC

Pin 4: Power