

Videosys Broadcast

IDU User Manual

Revision 3.0.1 01/05/2018

Videosys Broadcast Ltd

Unit 1-2 Forest Farm Barn

Turners Hill Road

Turners Hill

West Sussex, RH10 4QH

Tel: +44 1293 541200

www.videosys.tv

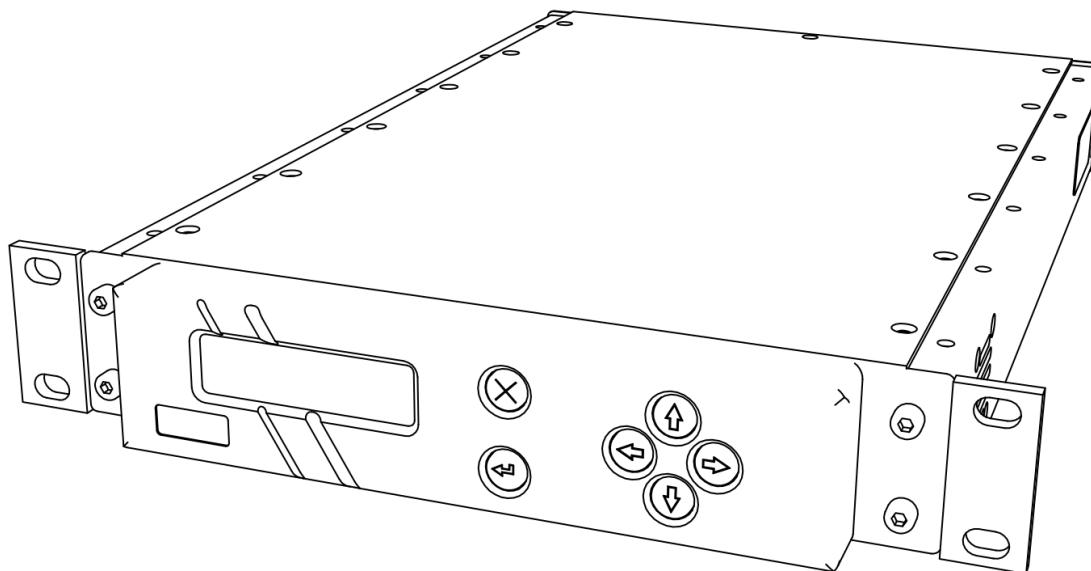

Contents

Your Camera Control Indoor Unit	3
Front Panel.....	3
Rear Panel.....	3
Getting Started	4
Introduction	4
Principal of Operation	4
Uni-directional	4
Bi-directional	5
Connecting Components	6
RCP	6
ODU	6
Tally	6
Power	6
Navigating Menus.....	7
Status Screens	7
Uni-directional Status Screen.....	7
Bi-directional Status Screen	7
Menu Structure	8
Web Interface.....	9
Accessing the Web Interface.....	9
Navigating the Web Interface	10
Unit Updates	11
Specification.....	12
Supported Cameras & Commands	12
Physical Parameters	12
Electrical Parameters	12
Backwards Compatibility	13
Connector Wiring Diagrams	13
Data Out.....	13
Power Input Connector	13
RCP legacy connectors	14
Generic Connectors	14
Sony Connectors.....	14
Bi-directional Data Return Port	15
Tally Input Connector	15

Your Camera Control Indoor Unit

Front Panel

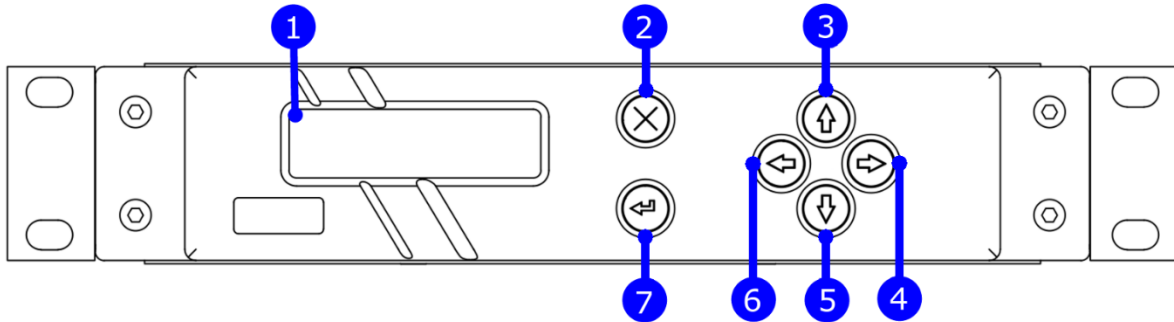

1. OLED Display
2. Cancel Button
3. Up Button
4. Right Button
5. Down Button
6. Left Button
7. Enter Button

Rear Panel

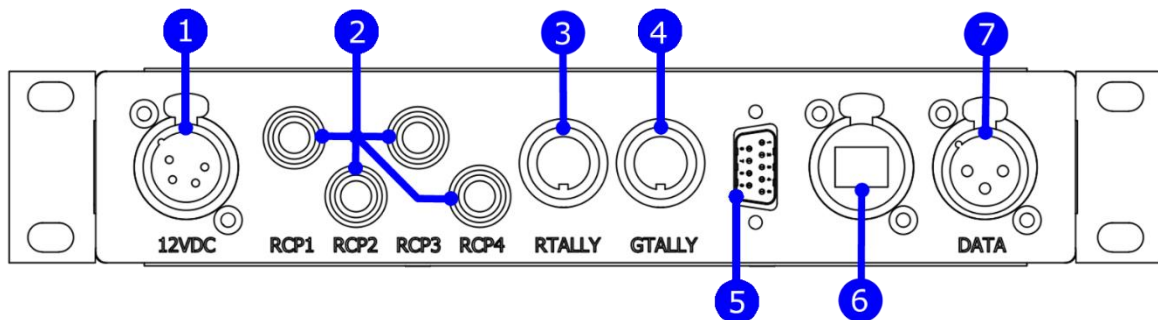

1. Power Input Connector (4 Pin XLR, Male)
2. Legacy Camera Connectors (Either 'Generic' or 'Sony' as specified upon ordering)
3. Red Tally Input Connector (8 pin DIN)
4. Green Tally Input Connector (8 pin DIN)
5. Bi-directional Data Return Connector (D9)
6. Ethernet Connector (RJ45)
7. Data Output Connector (3 Pin XLR, Female)

Getting Started

Thank you for purchasing a Videosys IDU, we hope that you will find the necessary information within this manual and our specific quick setup guides, if however, you require additional support please don't hesitate to contact your local distributor.

Introduction

The Videosys camera control system allows you to replace the cables between your Remote Control Panels, Camera Control Units and Cameras, the Videosys IDU connects directly to existing control panels and in combination with other components from the Videosys camera control range will provide a robust broadcast quality solution.

The Videosys camera control solution consists of three distinct components; an 'IDU' (In Door Unit), 'ODU' (Out Door Unit) and an 'RX' (Receiver). Multiples of these components can be used to best fit the operators' requirements, for example multiple IDU's can be connected to allow for many camera control paths over one ODU. Multiple ODU's can be used to increase RF coverage, and each camera to be controlled requires an RX.

From this point on to avoid ambiguity and keep things concise, the terms IDU, ODU, RCP and RX will be used.

Principal of Operation

Our camera control system can be configured to operate using one of two fundamentally different architectures, descriptions of the architectures and their relative advantages and drawbacks are as follows:

Uni-directional

In this mode the IDU acts as a 'Virtual Camera' and talks to the RCP via its native protocol. Changes to this Virtual Camera are then encoded into our low latency protocol. Encoded data is routed from the IDU to the ODU where it is transmitted. Data is then received via the RX, within the RX a 'Virtual Panel' is updated with the received information, the 'Virtual Panel' then communicates with the camera using its native protocol.

- This approach allows high performance even within an extremely poor RF environment; as data loss will not cause link failure.
- Uni-directional operation boasts simple setup, as only one data path needs to be configured.
- Due to the use of an intermediate protocol, Uni-directional operation allows operators to mix and match different manufacturers cameras and control panels.
- As each command has to be specifically implemented and handled, not all of the features available on manufacturers cameras and control panels will be available when used with a Uni-directional control link.

Bi-directional

In this mode an RCP natively communicates to the IDU, data is then conditioned and forwarded on to the ODU, where it is then transmitted. An RX then receives transmitted data and communicates with the manufacturers camera. Return data is fed from the RX via a return path, back to the IDU. Typically, this return path would be via the data path provided on many COFDM video transmitters.

- All of the features that would be available via a cabled setup are available via our Bi-directional setup.
- Due to the bandwidth restrictions of the RF path, RCP wakeup times might be slightly longer than in a wired or Uni-directional set up.
- Because of the reliance on two communication paths, wireless control is not as robust as with Uni-directional operation.

Depending on the specific requirements of your application, Bi-directional or Uni-directional should be selected.

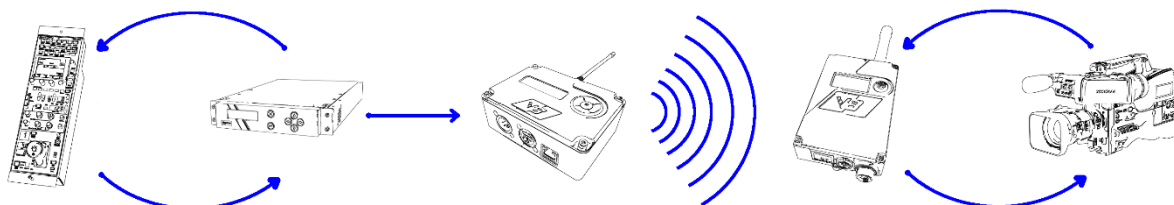

Fig 1. A simple uni-directional camera control setup

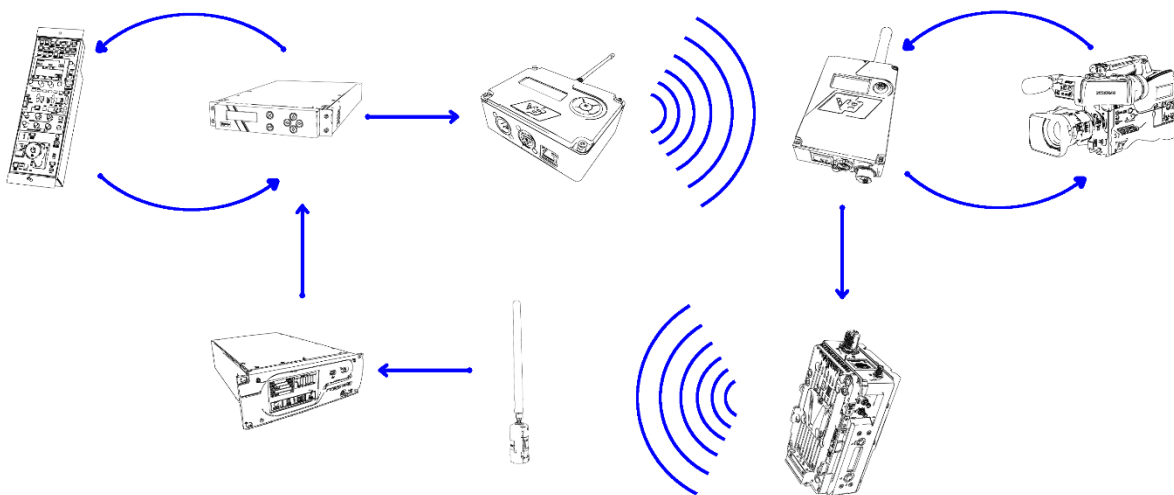

Fig 2. A simple bi-directional camera control setup utilising return via videolink data path

Connecting Components

The first step is to connect the components of your camera control system.

RCP

This can be connected via an Ethernet network using the RJ45 connector, or via the appropriate cable to the numbered legacy connectors on the back of the unit. A range of pre-made cables and cable wiring diagrams are available on our website or via contacting your local sales representative.

ODU

There are two options for connecting to an ODU, either via the Data Out Connector or using the RJ45 and via an Ethernet Network.

Tally

The IDU can be connected into an existing tally system via the Tally Input Connector, this will respond to contact closure, open collector input and TTL logic levels (inverted).

Power

Connect 12V DC to the Power input XLR connector. When powered the unit will display a boot screen and then present the user with a status screen.

Navigating Menus

The Up, Down, Left, Right, Enter and Cancel buttons can be used to navigate through the menus. Menus are organised into lists, these can be scrolled through with the Up and Down buttons. To enter the selected submenu or option, press the Enter button. Cancel will return you to previous menu, potentially discarding any unsaved changes made within the current menu. The Left and Right buttons are predominantly used to select which character is being edited in settings such as IP address or Frequency.

Status Screens

The first screen that will be displayed to the user is the status screen, depending on the mode that the unit is set to this will either be the Uni-directional control status screen (fig 1) or the Bi-directional control status screen (fig 2)



Fig 1. Uni-directional operation mode status screen

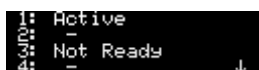

Fig 2. Bi-directional operation mode status screen

Uni-directional Status Screen

The Uni-directional control status screen has numbered rows that represent the RCPs that the IDU can connect to. There can be a maximum of four RCPs per IDU, although your unit may display less depending on licencing. Each RCP can have two states; Connected or Disconnected. When an IDU and panel are successfully communicating 'Connected' is displayed.

In Uni-directional mode the IDU does not know, and therefore cannot tell the user anything about the transmit, receive or RX to Camera connection status.

Bi-directional Status Screen

The Bi-directional status screen has numbered rows, each representing connection to a camera, these connections can have the following status:

'Not ready' – This states that a full bi-directional loop cannot be made, this could mean that a link to the camera or panel has not yet been established, or that there is a fault with either the forward or return path. You can use the up and down controls to scroll through the individual status pages for each of these connections.

'Sync...' – this states that all of the required links are up, and connections made, but that devices are 'waking up' and synchronisation data is being transferred, and it is therefore not usable for camera control. This process happens as soon as the required connections are made and typically takes a few seconds, depending on the camera manufacturer, manufacturer's hardware, software and feature count.

'Active' – All connections are good, camera parameters and values have been synchronised and the systems is ready to use.

Menu Structure

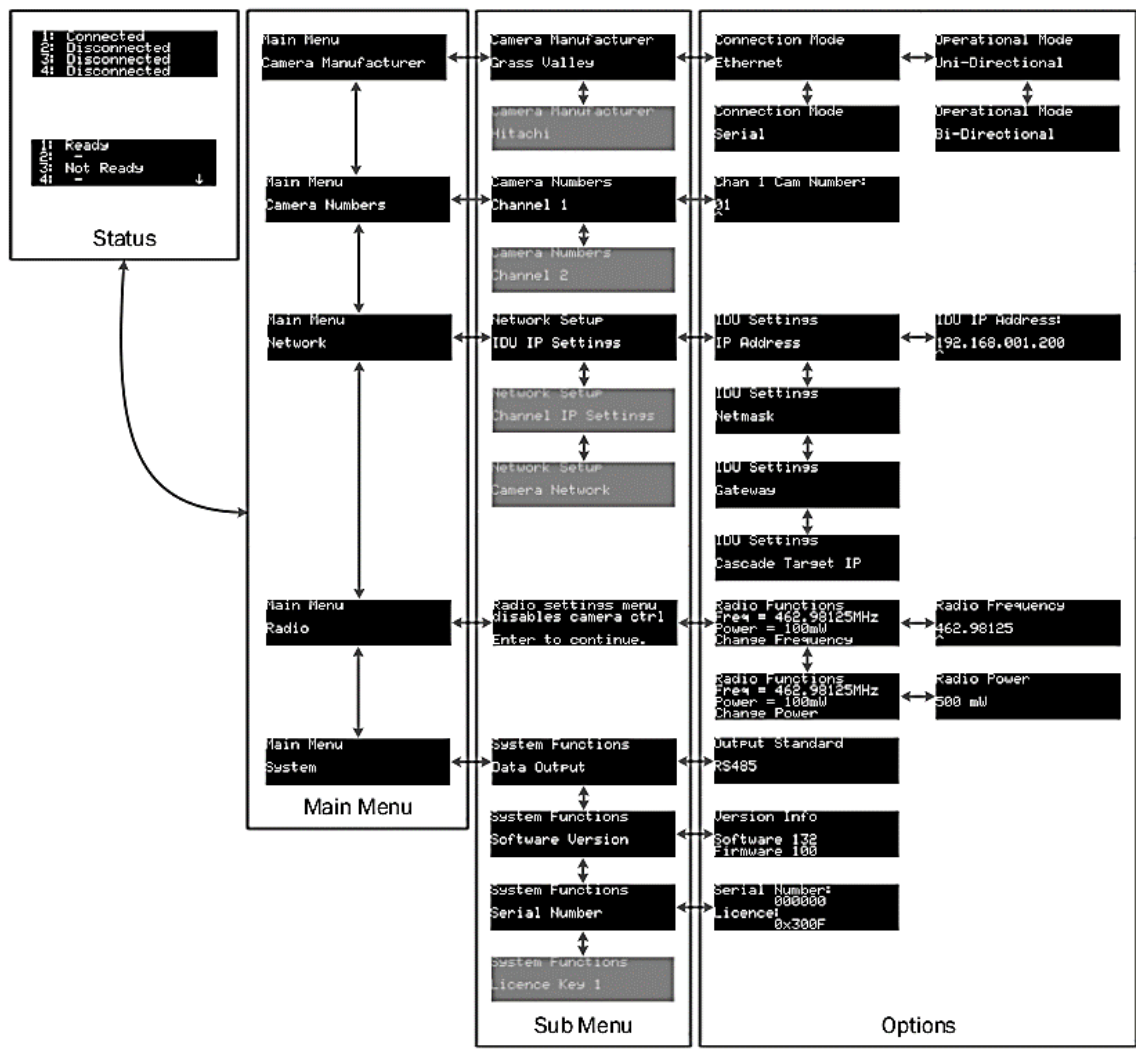

Fig 3. IDU menu structure diagram

Pressing enter will move the user from the status screen to the Main menu, this main menu allows the user to navigate to a category, these are as follows;

'CameraMfg' – Allows the user to select a camera manufacturer, depending on the camera it might also guide the user through menus asking which camera models are being used. There are then options for Serial, Ethernet, Bi-directional or Uni-directional.

'CameraNumbers' – Sets which camera numbers are matched to which channels, these camera numbers are used to specify which receiver is listening for that data.

'Network' – Contains submenus for the IDUs IP settings, Channel IP settings and Camera Network settings. Channel settings are the IP addresses for panels to connect to via IP. Camera Network settings has manufacturer specific settings such as specific ports to use for connection.

'Radio' – Communicates with an ODU that is connected via the data connector, displaying and allowing the user to modify the radio frequency and transmit power.

'System' – Contains a range of settings relating to the IDU itself, Serial numbers, Licence options, Data output, Paint settings reset and version information.

Web Interface

The IDU has a built-in webserver and serves a range of useful control pages, if you have a device with a web browser on the same network, you can use this interface to quickly change settings, perform updates and utilise the virtual RCP feature.

Accessing the Web Interface

To Access the Web interface, firstly power up your IDU and connect a PC or laptop up to the same IP network as your IDU. Find the IP address of your IDU (this can be found via Network -> IDU settings -> IDU IP Address) and enter this into your browser, this will take you to the IDUs configuration web page.

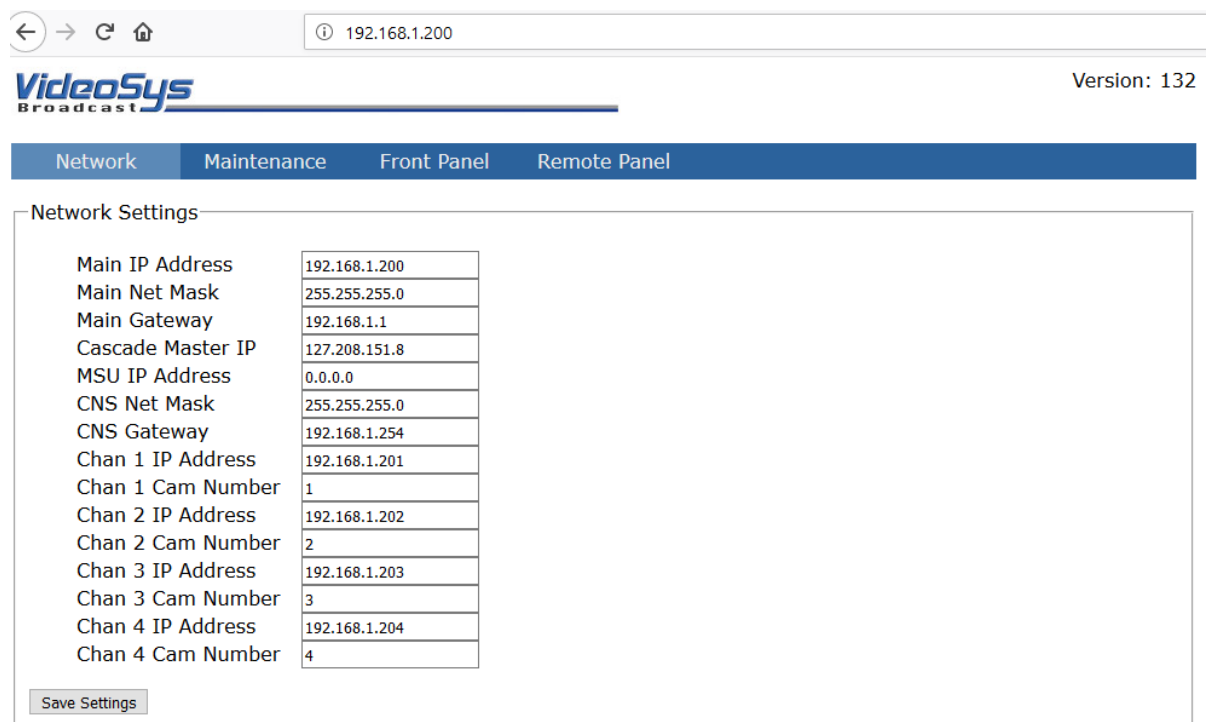

Fig 4. The IDUs Network Configuration Webpage

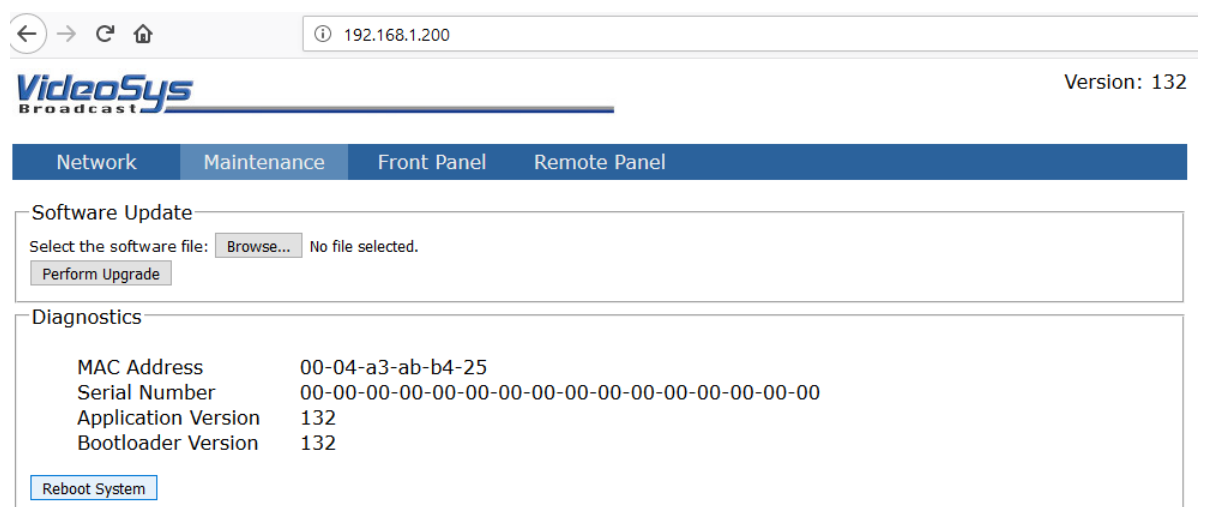

Fig 5. The IDUs Maintenance Webpage

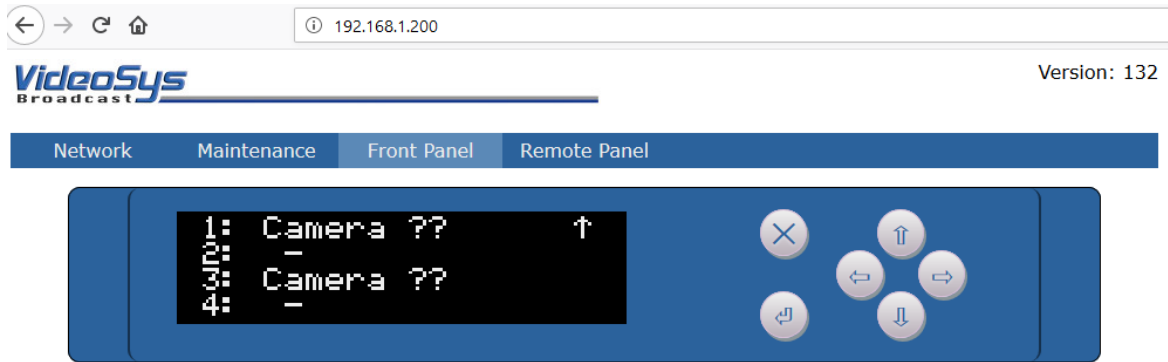

Fig 6. The IDUs Front Panel Webpage

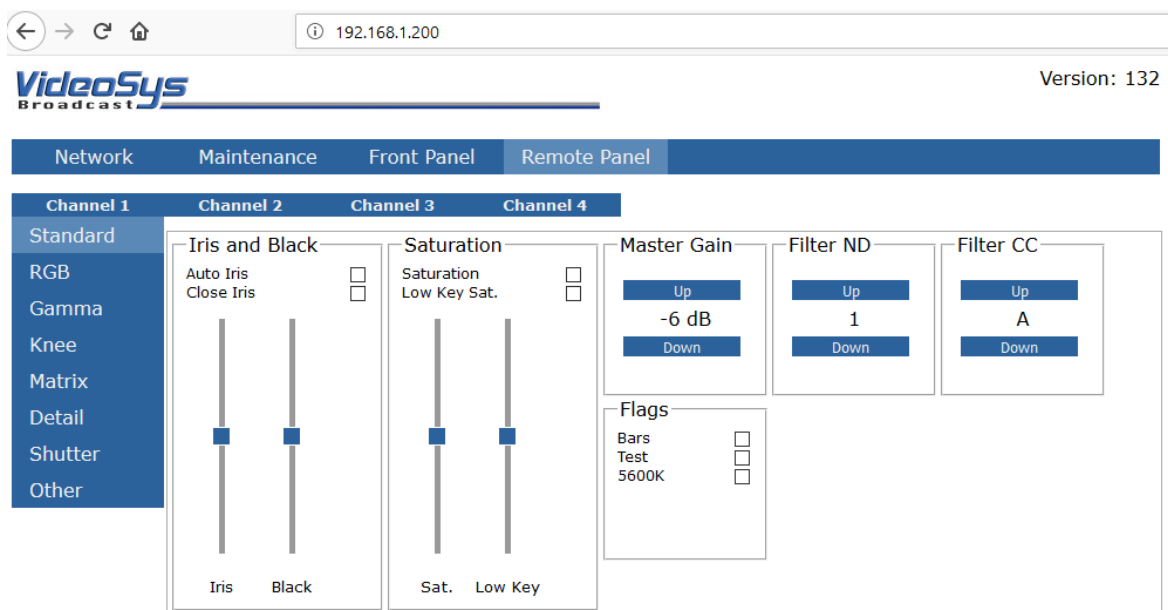

Fig 7. The IDUs Remote Panel Webpage

Navigating the Web Interface

Once you have loaded the webpage (see 'Accessing the Web Interface'), you should see the 'Network' Page (fig 4), from this page you can easily and quickly configure the unit as part of an IP network. There is also a 'Maintenance' page (fig 5), giving device information and allowing for updates (these can be found on our website). The 'Front Panel' page (fig 6) literally mirrors the information presented on the IDUs front panel and allows for all of the same functionality as the units' physical front panel. There is also a 'Remote Panel' page (fig 7); this is a 'Virtual RCP' and allows for all of the settings that we support in Uni-Directional mode to be controlled directly from the browser.

Unit Updates

To update your IDU, firstly you will need to obtain a new firmware image, these are available on our website. Please check the release notes bundled with the firmware images carefully, they will explain precisely what changes have been made. The next step is to access the webpage (see 'Accessing the Web Interface'). On the 'Maintenance' page fig 5. you will find a software update section, use this to select and upload the file. During the update you will notice that the IDU will inform you that it is restarting and then that it is updating. If you have any questions about which firmware image you should be using or require any additional support please your local distributor.

Specification

Supported Cameras & Commands

The vast majority of commands that would be used day to day are available via Uni-directional control, and the full command set should be available via Bi-directional control.

For a full list of supported cameras and commands please see the software release notes provided with our software updates, software updates are regularly released and we hope to keep our range of supported cameras expanding. If you do not find the information you are looking for or would like assistance, please contact us.

Physical Parameters

Dimensions

Width: 220mm excluding rack ears
262mm with rack ears.

Height: 44mm

Length: 349mm

Weight:

Weather proofing: None

Temperature Range: 0-50 °C

Sound Output: None - Fanless

Electrical Parameters

Operating Voltage: 9-18V

Current Consumption: > 1A

Be aware that RCPs can be powered up via the IDU, this will increase the current draw significantly.

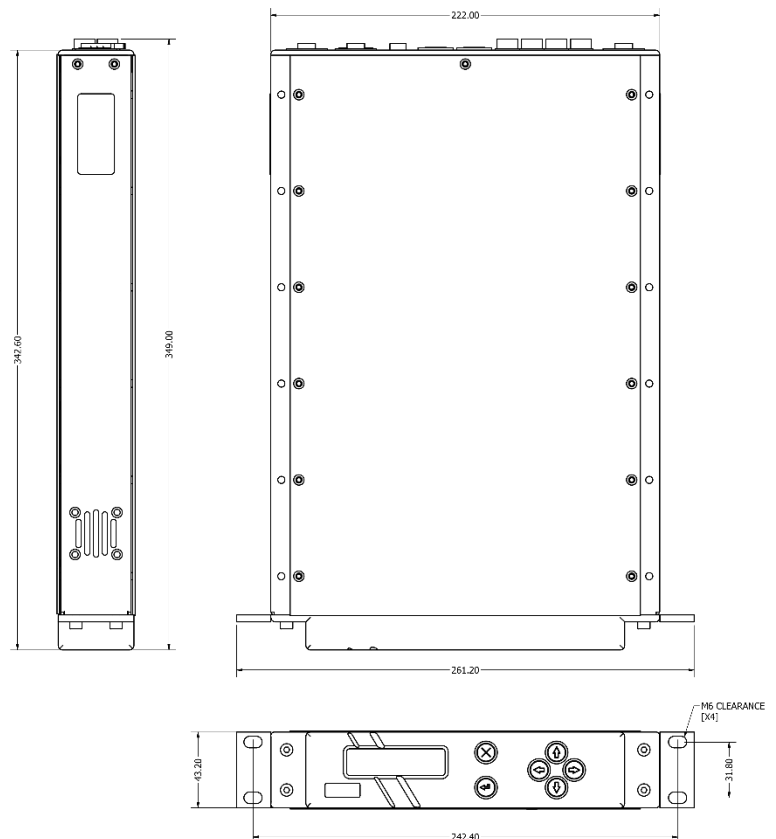

Backwards Compatibility

We have multiple generations of hardware, which due to our commitment to backwards compatibility can, in the vast majority of cases, still be used to build a high-performance camera control system. If you are integrating new components into a previous generation system however, some of our latest features might not be available. Please check our software release notes for the version that you are running or contact our sales department for more information.

Connector Wiring Diagrams

The following diagrams are from the point of view of the rear panel of the IDU facing the user.

Data Out

3-Pin XLR, Female, *NEUTRIK NC3FD-LX -HD*

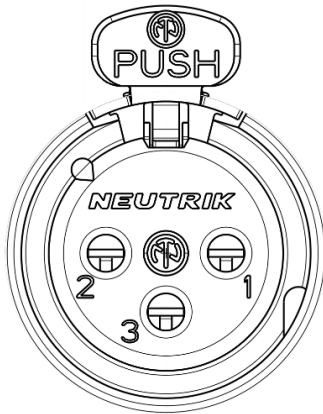

Pin 1: Ground

In RS232 Mode:
Pin 2: RS232 Tx
Pin 3: RS232 Rx

In RS484 Mode
Pin 2: RS485 Data -
Pin 3: RS485 Data +

Power Input Connector

4-Pin XLR, Male, *NEUTRIK NC4MD*

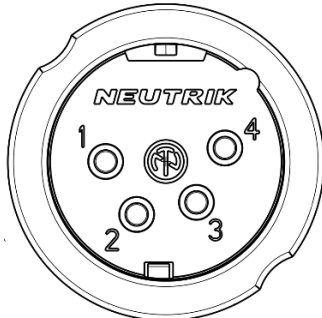

Pin 1: Ground
Pin 2: NC
Pin 3: NC
Pin 4: Power

RCP legacy connectors

Generic Connectors

10-pin, Female, *HIROSE HR10A-10R-10S(71)*

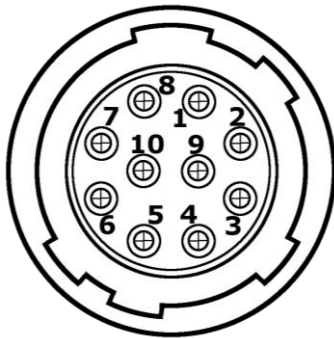

- Pin 1: RS422 TX +
- Pin 2: RS422 TX -
- Pin 3: RS422 RX +
- Pin 4: RS422 RX -
- Pin 5: Ground
- Pin 6: RS232 RX
- Pin 7: RS232 TX
- Pin 8: NC
- Pin 9: Power
- Pin 10: Ground

Sony Connectors

8-Pin, Female, *HIROSE MXR-8RA-8S(71)*

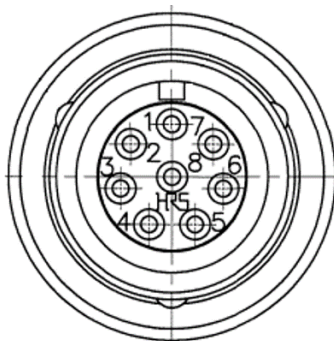

- Pin 1: RS422 TX +
- Pin 2: RS422 TX -
- Pin 3: RS422 RX +
- Pin 4: RS422 RX -
- Pin 5: Ground
- Pin 6: Power
- Pin 7: Ground
- Pin 8: NC

Bi-directional Data Return Port

D-sub 9 pin, Male, AMPHENOL G17S0910110EU

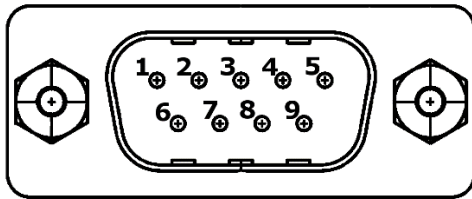

Pin 1: RS232 Rx (CH1)
Pin 2: RS232 Rx (CH2)
Pin 3: RS232 Rx (CH3)
Pin 4: RS232 Rx (CH4)
Pin 5: Ground

Pin 6: Ground
Pin 7: Ground
Pin 8: Ground
Pin 9: NC

Tally Input Connector

8-Pin DIN, Female, LUMBERG KFV 80

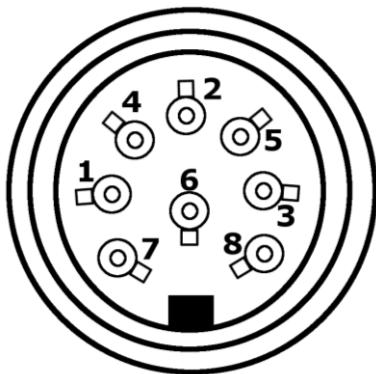

Pin 1: Ground
Pin 2: Ground
Pin 3: Ground
Pin 4: Input 2
Pin 5: Input 3
Pin 6: Ground
Pin 7: Input 1
Pin 8: Input 4