

Resource Identifier 100249

Revision: 2.1



AEON Transmitter and Decoder User Guide



Commercial in Confidence

0. Preface

0.1 About this Document

This document contains relevant information required to identify, install and control the equipment or system.

Since the available functions can be licensed and depend on the specific implementation, not all the functions and or applications contained in this document may be relevant or applicable to the system you will be working with.

The actual presentation may differ from those in this document due to hardware or software changes.

0.2 Intended Audience

This document is meant for anyone interested in how the system can best be used, but it is of most benefit to:

- **Operators** who oversee the daily operation of the equipment
- **Installers** who are responsible for the pre-installation, on-site installation and configuration of the system in the end-user environment
- **Maintainers** who are responsible for maintaining the equipment or system

0.3 Notice about this Publication

While DTC makes every attempt to maintain the accuracy of the information contained in its product manuals, the information is subject to change without notice.

Performance specifications included in this manual are for guidance. All particulars are given by DTC in good faith, actual performance may vary.

0.4 Text Conventions

This document uses these conventions to identify text that has a special meaning:

Text Convention	Example
TEXT in capitals represents a key press on the keyboard. The + sign means hold down the first key and press the second key.	ESC, F1, SHIFT CTRL+C
<Text> Serves as a placeholder for variable text that is replaced as appropriate, the text may be written in italics.	Use the filename <system_name>.sys for...
Text in italics can represent a link to place in the existing document (often these are hyperlinks) or a reference to another document.	Refer to <i>Section 0.4, Text Conventions</i> .
Text in bold emphasises a new word or term of significance.	We call this a protocol and its function is...
Successive software menu selections are shown using arrows to indicate sub-menus. This is often shown in bold.	Select Configuration>Global then edit...

0.5 Symbols

This document uses these symbols to highlight important information:

WARNING: A notice of when a situation may result in personal injury or loss of life, or destruction of equipment.

CAUTION: A notice of when a situation may result in loss of data or damage to equipment or systems.

Note: A notice to draw attention to something or supply additional information.

0.6 Copyright Statement

This document contains information that is proprietary to Domo Tactical Communications (DTC) Ltd. Any copying or reproduction in any form whatsoever is prohibited without the written permission of DTC.

© 2018 Copyright Domo Tactical Communications (DTC) Limited. All rights reserved.

0.7 Related Documents

You may also need to refer to:

Document	Source
NETNode Phase 5 Software User Guide	DTC
Solo Concept Guide	DTC
IP Concept Guide	DTC

0.8 Document History

This is a controlled document, written and produced by the DTC Technical Publications team. Changes are recorded in the table below.

Revision	Date	Author	Summary of Changes
1.0	06/02/2018	IR	First release
1.1	23/08/2018	IR	Decoder rear panel amendments, upgrade procedures and decoder configurations.
1.2	11/09/2018	IR	USB supported dongles. Removed USB slot from Decoder. Record playback syntax.
2.0	14/08/2019	IR	Software updates and case temperature caution.
2.1	30/03/2020	IR	Amended SDI input 3 to include 12G-SDI. Support for 8 channel audio. Software updates for 5.2.0.

Contents

0. Preface.....	0-1
0.1 About this Document	0-1
0.2 Intended Audience	0-1
0.3 Notice about this Publication.....	0-1
0.4 Text Conventions.....	0-2
0.5 Symbols	0-2
0.6 Copyright Statement	0-2
0.7 Related Documents.....	0-3
0.8 Document History.....	0-3
1. Product Overview	1-1
1.1 Product Family.....	1-1
1.2 AEON Transmitter	1-1
1.3 AEON Decoder	1-3
2. Product Package	2-4
2.1 Overview	2-4
2.2 AEON Transmitter Parts List	2-4
2.3 AEON Decoder Parts List	2-4
2.4 Accessory Options	2-5
2.5 AEON Transmitter Licensing Options	2-5
2.6 AEON Transmitter Variants	2-6
2.7 Labelling.....	2-7
3. Connections, Controls and Indicators	3-8
3.1 Introduction	3-8
3.2 AEON Transmitter	3-8
3.3 AEON Rack Decoder	3-14
4. Getting Started	4-16
4.1 Power.....	4-16
4.2 Access the USB Stick	4-16
4.3 Node Finder Application	4-17
4.4 AEON Transmitter Web Browser Control.....	4-19
4.5 Web Browser Control	4-20
4.6 LCD/OLED Display Control.....	4-20
5. AEON Transmitter Web Browser Operation.....	5-21
5.1 Introduction	5-21
5.2 Unit Status>Overview Tab	5-21
5.3 Unit Status>Service Tab.....	5-22
5.4 Unit Status>SDI/SFP Tab.....	5-22
5.5 Configuration Tab – Apply, Save and Refresh	5-23

5.6	Configuration>Global Tab	5-23
5.7	Configuration>Unit Tab.....	5-30
5.8	Configuration>Encoder Tab.....	5-31
5.9	Configuration>Audio Tab	5-32
5.10	Configuration>Data Tab	5-35
5.11	Configuration>Streamer.....	5-36
5.12	Configuration>Modulator Tab.....	5-40
5.13	Engineering>Information Tab.....	5-45
5.14	Engineering>Calibration Tab.....	5-45
5.15	Engineering>Uploads	5-46
5.16	Engineering>Configs	5-48
6.	AEON-MESH Web Browser Operation.....	6-49
6.1	Introduction	6-49
6.2	AEON-MESH with AEON Encoder	6-50
6.3	AEON-MESH with SDR Dual Encoder	6-51
7.	AEON Transmitter LCD Display Operation	7-53
7.1	Overview	7-53
7.2	Icons and Controls	7-53
7.3	Navigating the Menu	7-54
8.	AEON Decoder Operation	8-55
8.1	Introduction	8-55
8.2	OLED Display.....	8-55
8.3	Menus	8-56
8.4	Software Upgrades	8-57
9.	Example Applications.....	9-59
9.1	Single AEON 4K HEVC System	9-59
9.2	MESH Application.....	9-62
10.	Appendix A – Reference Material	10-65
10.1	How to Configure a PC IP Address.....	10-65
10.2	AEON Transmitter Pinouts.....	10-66
10.3	AEON Decoder Pinouts.....	10-69
11.	Appendix B – After Sales Support	11-71
11.1	Documentation and Software.....	11-71
11.2	Contact Technical Support.....	11-71
11.3	Using the DTC RMA Service.....	11-71
12.	Appendix C – Safety and Maintenance	12-73
12.1	Cautions and Warnings.....	12-73
12.2	Repairs and Alterations	12-74

12.3	Caring for your Equipment	12-74
12.4	Charging	12-74
12.5	Working with Lithium Batteries.....	12-75
12.6	Cleaning.....	12-75
12.7	Storage.....	12-75
13.	Appendix D – Glossary	13-77

1. Product Overview

1.1 Product Family

The subject equipment of this user guide is:

Product Code	Product Description
AEON-TX	AEON HEVC Transmitter
AEON-DEC	AEON 4K Decoder

1.2 AEON Transmitter



1.2.1 Description

A compact and feature rich COFDM digital video transmitter, specifically designed for high quality wireless link applications. With proven Domo COFDM and next generation HEVC encoder technology at its core enabling Ultra High Definition images the small size and actively cooled enclosure give maximum operational performance. Designed to offer future proof connectivity, the unit supports native 12G-SDI, dual 6G-SDI, quad 3G-SDI, as well as SFP+ expansion. Two true balanced audio inputs are included with phantom power. The transmitter has an integrated control panel with sunlight-readable LCD display covering all major functions and has 16 user-defined presets, as well as IP based control.

The HEVC codec used in AEON products offers a step change in compression efficiency over H.264 systems, whilst maintaining low end to end latency suitable for live events.

1.2.2 Features

- Ultra-low latency HEVC SD, HD and 4K encoding
- Video formats up to 2160p60, 10-bit and 4:2:2 chroma sampling
- Industry standard DVB-T modulation for interoperability with existing systems
- Domo Broadcast UML modulation for enhanced high frequency/high speed performance
- Controlled via IP or integrated sunlight-readable LCD display
- Designed for sports and events coverage, newsgathering and wireless studio camera applications
- Low power consumption and active cooling for extended field performance

1.2.3 Basic Specifications

Dimensions	L 190mm (170mm excluding connectors) W 115mm, (105mm excluding connectors) D 55mm (without battery plates) or D 89mm (with V-Lock plates) or D 82mm (with Anton Bauer plates)
Weight	1576g
DC Input	9.2 to 17.8V reverse polarity protected
Power consumption	Typically 30.0W @ 100mW RF power and 4K video
Temperature range	-10°C to +50°C

Note: Detailed technical specifications are provided in the product datasheet. Please see <http://www.domotactical.com/products/wireless-broadcast-solutions/>.

1.3 AEON Decoder



1.3.1 Description

The AEON HEVC Rack Decoder provides low latency HEVC Ultra High Definition decoding from ASI/IP input. Ideal for adding decode support for the AEON Transmitter to existing receiver systems. Each decoder can support single 4K or up to two HD streams via quad 3G-SDI outputs and has two stereo balanced audio outputs available. The decoder has an integrated control panel with sunlight-readable OLED display covering all major functions, as well as IP based control.

The HEVC codec used in AEON products offers a step change in compression efficiency over H.264 systems, whilst maintaining low end to end latency suitable for live events.

1.3.2 Features

- Ultra-low latency HEVC SD, HD and 4K decoding with tri-level sync genlock
- Video formats up to 2160p60, 10-bit and 4:2:2 Chroma sampling, future HDR support
- Controlled via IP or integrated sunlight-readable OLED display
- Designed for sports and events coverage, newsgathering and wireless studio camera applications
- Scalable decoding platform supporting single 4K or two HD services
- Low power consumption and active cooling for extended field performance
- Compact 1/2 1RU rack form factor

1.3.3 Basic Specifications

Dimensions	180mm (L), 222mm (W), 43mm (W)
Weight	1155g
DC Input	12V to 17V
Power consumption	Typically 16.0W with 4K decoding
Temperature range	-10°C to +50°
Humidity	Less than 85% non-condensing

Note: Detailed technical specifications are given in the product datasheet. Please see <http://www.domotactical.com/products/wireless-broadcast-solutions/>.

2. Product Package

2.1 Overview

Carefully open the packaging and remove the device. Verify that all the components have been included in the package as shown in the packing list. Inspect the unit for shipping damage.

Note: If you don't have all the parts or you are not happy with the condition of your delivered product, please call DTC and we'll get this solved for you. See *Section 11.2*.

Retain the packing list and all the packing materials for storage. The codes mean:

- CA – cable assembly
- SA – sub assembly
- AP – assembly part

The codes are useful for identification and if you need to order a new part at some time.

2.2 AEON Transmitter Parts List

Part Number	Description
AEON-TX	AEON HEVC Transmitter
CA0579	XLR audio input cable
CA3348	AEON-TX UHD BNC to R/A HD-BNC 1855A 250mm cable
SA4075	AEON HEVC support USB stick consisting: Node Finder application, AEON User Guide

2.3 AEON Decoder Parts List

Part Number	Description
AEON-DEC	AEON HEVC Rack Decoder
CA0512	XLR audio output cable
CA0649	XLR 12V 6.67A 80W desktop PSU
SA4075	AEON HEVC support USB stick consisting: Node Finder application, AEON User Guide

2.4 Accessory Options

If you have purchased these options, they will also be in the package.

Part Number	Description
PRORXD-1RU	Professional Receiver 1RU
PRORXD-2RU	Professional Receiver 2RU
SOL8KF-043	Three button key fob (433.05-434.79MHz)
CA0340	RS-232 data input cable
CA3421	0B Lemo 15V 6.0A 90W desktop PSU

2.5 AEON Transmitter Licensing Options

Device licensing is viewable from the web browser software control application. See *Section 5.13*.

Part Number	Description
Silver (included)	DVB-T, Ultra Mobile Video Link (UMVL), Single HD Encoder
Gold	Silver plus DVB-T2 (future development)
Platinum	Gold plus Single 4K and Quad HD Encoder
AEON-TX-HDUP	Additional transmitter HD license
AES128TX	AES128 encryption
AES256TX	AES256 encryption

2.6 AEON Transmitter Variants

2.6.1 Product Code

This part number will be on the AEON-TX label. This will identify which variant has been delivered to you.

Part Number	Product Description
AEON-TX-AB-198750D-044	AEON-TX 1.98-2.70GHz, 6.40-7.50GHz, 410-480MHz telemetry, AB-mount
AEON-TX-V-198750D-044	AEON-TX 1.98-2.70GHz, 6.40-7.50GHz, 410-480MHz telemetry, V-mount
AEON-TX-AB-440500-043	AEON-TX 4.40-5.00GHz, 433.05-434.79MHz telemetry, AB-mount
AEON-TX-V-440500-043	AEON-TX 4.40-5.00GHz, 433.05-434.79MHz telemetry, V-mount

2.6.2 Dual Band Frequency Code

Where the COFDM frequency is dual band, the primary frequency will transmit on ports **Tx/RX A** and **Tx/Rx B** and the secondary frequency band will transmit on **Tx C** only.

For example:

198750 = 1.98-2.70GHz (Tx/RX A and Tx/Rx B) and 6.40-7.50GHz (Tx C only)

Note: This will be configured using the web browser control application, see *Section 5.12*.

2.7 Labelling

This topic contains information covering labels and markings on your device. The legend and location of each label or marking will be identified and explained for safety or maintenance significant information.

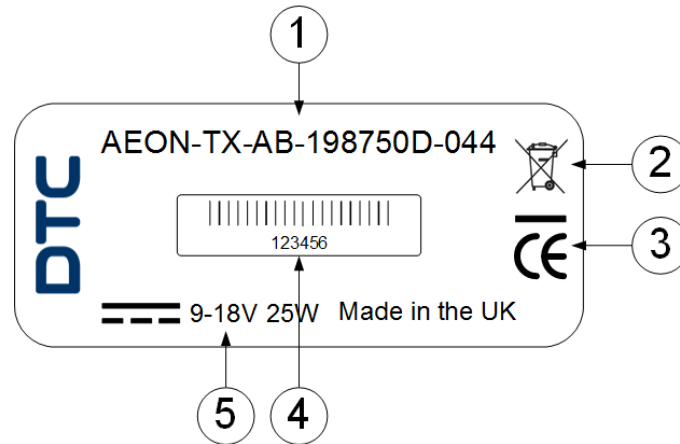

Figure 2-1 AEON Label

No.	Description
1	Product code – this will include the product name, battery mount and variant.
2	Indicates that the unit should be disposed of in accordance with the WEEE Directive.
3	The CE marking certifies that a product has met EU consumer safety, health and environmental requirements.
4	Barcoded six-digit serial number. This may be required during a support call.
5	Power requirements.

3. Connections, Controls and Indicators

3.1 Introduction

This chapter will help you identify all the connections and interfaces to help you install and control the AEON Transmitter or Decoder.

3.2 AEON Transmitter

The **AEON-TX** has several facets which have been given nominal titles; Top Panel, Bottom Panel, Left Panel (LCD), Right Panel, Camera Mount Plate and Battery Mount Plate.

3.2.1 Top Panel

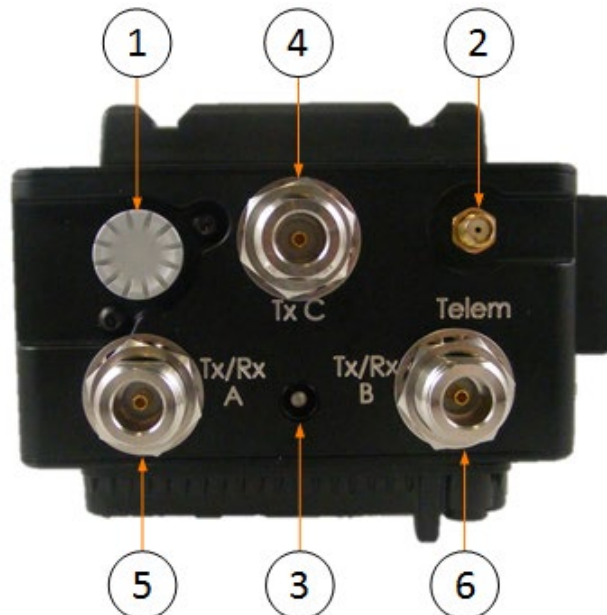

No.	Item	Purpose
1	LCD display control knob	Knob can be rotated and pushed up, down, left and right to navigate the LCD display menu. Left/right moves through the menu levels Up/down changes the menu selection Rotate to change a value Short push to enter a value. Note: For full details of LCD display operation, refer to <i>Chapter 7</i> .
2	SMA socket	Telemetry antenna connector.
3	LED indicator	Power/RF status: Red = unit has booted up, no RF power Green = RF output on (TX mode) or in link (Mesh mode)

No.	Item	Purpose
4	N-type socket	<p>COFDM TX only antenna C connector. Read note below.</p> <p>This port transmits in the secondary frequency band. See <i>Section 2.6.2</i>.</p> <p>When transmitting in this band, port C is the only TX output.</p>
5	N-type socket	<p>COFDM TX/RX antenna A connector. Read note below.</p> <p>This port transmits in the primary frequency band. See <i>Section 2.6.2</i>.</p> <p>When transmitting in this band and configured as a SOL-TX, this will be a selectable TX only port.</p> <p>When configured as a MESH, it can become a TX/RX port.</p>
6	N-type socket	<p>COFDM TX/RX antenna B connector. Read note below.</p> <p>This port transmits in the primary frequency band, 1.98–2.7GHz or 4.4–5GHz or 5.5–6GHz.</p> <p>When transmitting in this band and configured as a SOL-TX, this will be a selectable TX only port.</p> <p>When configured as a MESH, it can become a TX/RX port.</p>

Note: The transmit port selection is achieved by selecting the modulation frequency in the web browser control application, see *Section 5.12*.

3.2.2 Bottom Panel

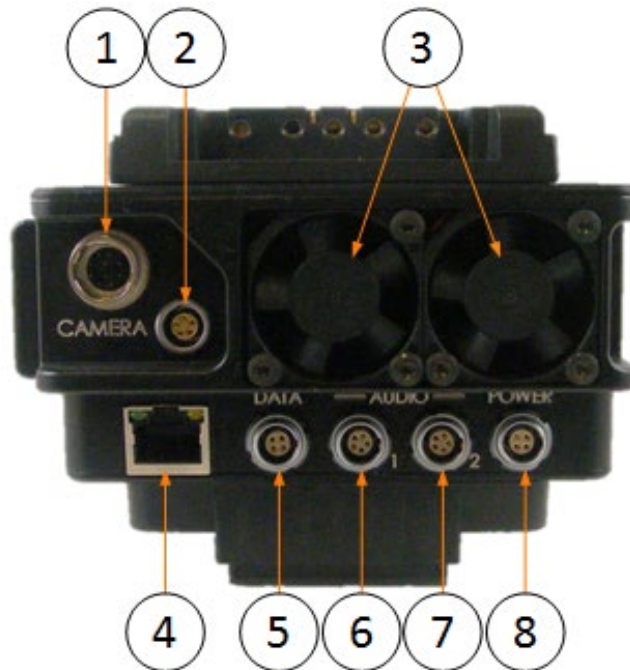

Note: See *Section 10.2* for pinout where relevant.

No.	Item	Purpose
1	Hirose 10-way jack (pins)	Data and power to the camera.
2	Lemo 5-way jack (sockets)	Tally light control.
3	Fans	Provides cooling for internal components. Take care not to obstruct.
4	RJ45 jack	Ethernet connection for IP control and video streaming.
5	Lemo 4-way jack (sockets)	RS-232 data interface.
6	Lemo 5-way jack (sockets)	Channel 1 balanced left and right audio input with switchable 48V phantom power.
7	Lemo 5-way jack (sockets)	Channel 2 balanced left and right audio input with switchable 48V phantom power.
8	Lemo 4-way jack (sockets)	12V DC input (9.2V – 17.8V).

3.2.3 Right Panel



No.	Item	Purpose
1	High density BNC socket x 2	ASI video IN and OUT. Note: ASI IN can be set up as an SDI input when the AEON Mesh is configured as an SDR Dual Encoder (see <i>Section 6.3.4</i>).
2	3.5mm jack socket x 2	Microphone and headphone audio for talkback.
3	High density BNC socket x 4 Note: 6G/12G-SDI inputs are marked by a circle around the connector.	SDI video input 1. Supports 12G-SDI (single input), 6G-SDI (dual input) or 3G-SDI (quad input). The supplied CA3348 cables will adapt the HD-BNC connectors to BNC.
		SDI video input 2. Supports 3G-SDI (quad input). The supplied CA3348 cables will adapt the HD-BNC connectors to BNC.
		SDI video input 3. Supports 12G-SDI (single input), 6G-SDI (dual input) or 3G-SDI (quad input). The supplied CA3348 cables will adapt the HD-BNC connectors to BNC.
		SDI video input 4. Supports 3G-SDI (quad input). The supplied CA3348 cables will adapt the HD-BNC connectors to BNC.
4	USB jack	USB host or peripheral device connection. See <i>Section 5.6</i> for supported Wi-Fi and 4G dongles.
5	SFP+ jack	Can be used for a single 12G-SDI or dual 6G-SDI input. Note: This will override SDI input 1 or 3 when using 12G-SDI. One channel may be used in conjunction with SDI input 1 or 3 when using 6G-SDI as a dual input.

No.	Item	Purpose
6	D-tap supply	This terminal can tap up to 50W of power from the battery for auxiliary use.

3.2.4 Left Panel (LCD)

Note: For full details of LCD display operation, refer to *Chapter 7*.

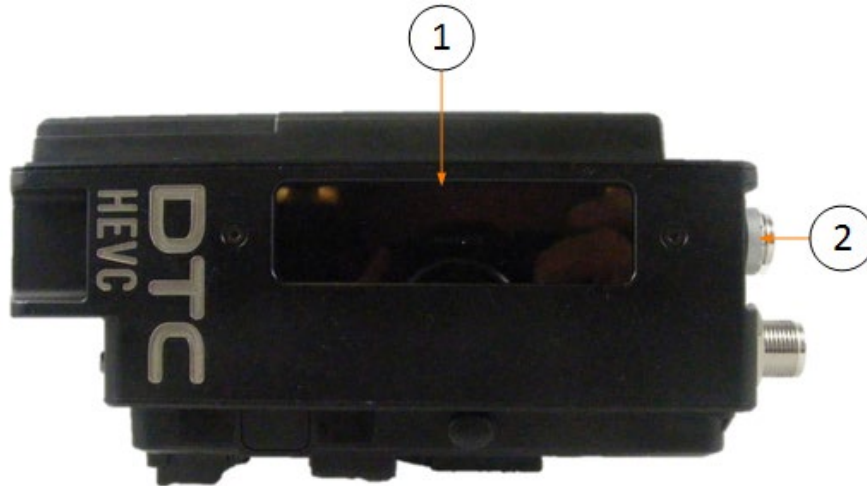

No.	Item	Purpose
1	LCD display	A sunlight-readable LCD display covering all major functions.
2	LCD display control knob	Use this knob to navigate the LCD display menu.

3.2.5 Camera Mount Plate

The AEON-TX camera mount plate will assemble the AEON-TX to the camera. The AEON-TX will have either an AB or V mount option.

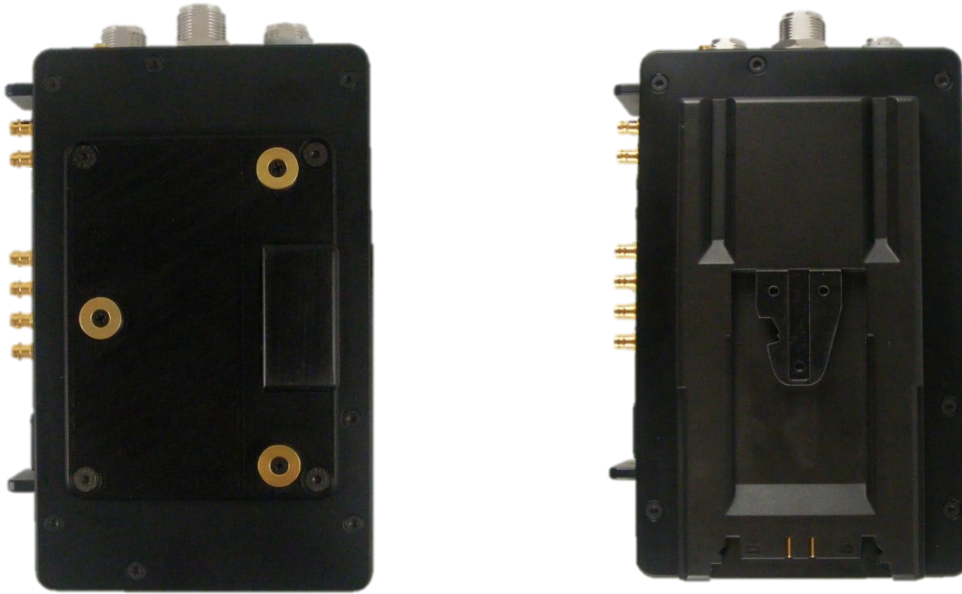

Figure 3-1 AB Camera Mount (left) and V Camera Mount (right)

3.2.6 Battery Mount Plate

The AEON-TX battery mount plate will assemble the battery to the AEON-TX. The AEON-TX will have either AB or V mount option.

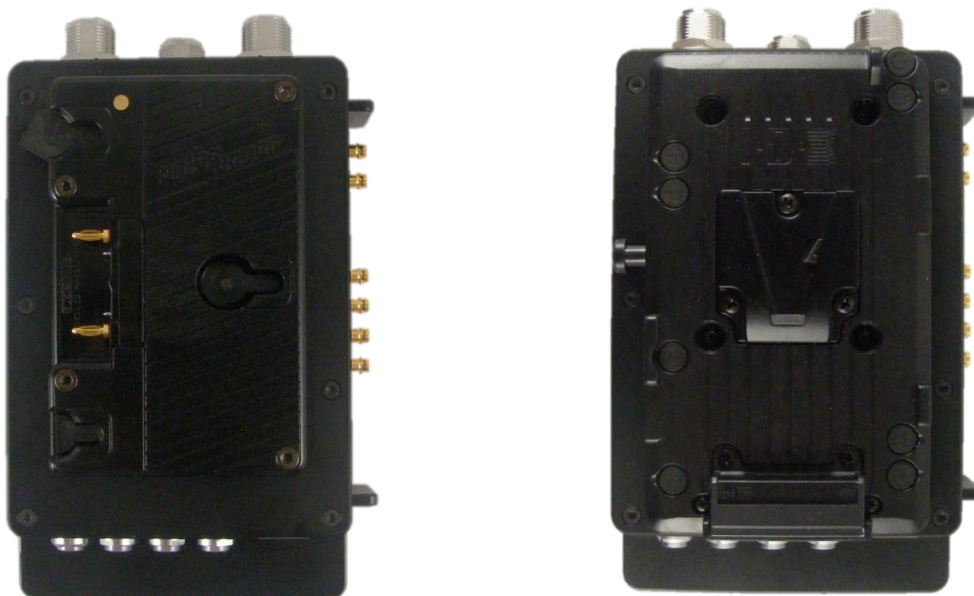
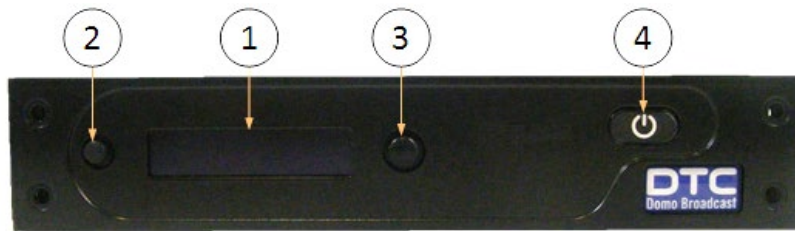

Figure 3-2 AB Battery Mount (left) and V Battery Mount (right)

3.3 AEON Rack Decoder

3.3.1 Front Panel



No.	Item	Purpose
1	OLED display	A sunlight-readable OLED display covering all major functions.
2	Cancel button	Each time you push the button, the menu moves back a level.
3	Navigation button	Push the Navigation button to select menus or options. Move the button up and down to move between menus or change options. Move the button left and right to select numbers/letters when editing values.
4	Power button	Push to toggle the power on or off.

3.3.2 Rear Panel

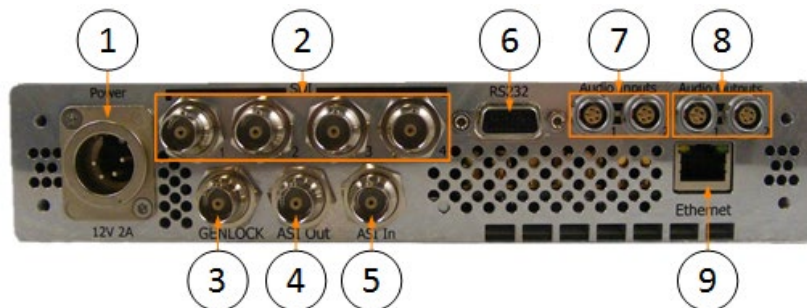

Note: See *Section 10.3* for pinout where relevant.

No.	Item	Purpose
1	XLR 4-way jack (pins)	Use the supplied CA0649 PSU to supply 12V DC input (9V – 18V) to the unit.
2	BNC jack (socket) x 4	3G-SDI Level A video outputs.
3	BNC jack (socket)	Genlock input to keep the Decoder synchronised with all the other equipment in your facility.
4	BNC jack (socket)	ASI video output.
5	BNC jack (socket)	ASI video input.

No.	Item	Purpose
6	9-way D-type connector (sockets)	RS-232 data communications.
7	5-way Lemo jack (sockets) x 2	Non-functional on the decoder.
8	5-way Lemo jack (sockets) x 2	Channel 1 and 2 balanced left and right audio output, use supplied CA0512 cable.
9	RJ45 jack	Ethernet connection for software upgrades.

4. Getting Started

4.1 Power

4.1.1 AEON Transmitter

There is no power switch, the AEON Transmitter will start the moment the power supply is connected.

Power can be supplied to the AEON Transmitter in two ways:

- Via a battery – AB or V mount depending on the device battery mounting plate
- Via 9.2–17.8VDC input to the power connector on the bottom panel

CAUTION: Precautions may need to be taken to avoid burns when operating the AEON-TX in high ambient temperatures due to excessive heat from the unit metalwork.

4.1.2 AEON Decoder

Power to the AEON Decoder is supplied via the 12–17V DC input on the rear panel via the supplied **CA0649** 12V PSU. Power on/off is controlled by the front panel switch.

Push and release to switch on, the switch will latch. Push and release to switch off, the switch will unlatch.

4.2 Access the USB Stick

The USB support stick includes this user guide plus **Node Finder**, an application which you will need to establish the AEON Transmitter IP address.

1. Plug the USB stick into the USB port of your PC.
2. The USB stick device drivers will load the first time you plug it in to your PC. Wait for the drivers to load successfully, you should see the progress in the bottom right of your PC screen.
3. Once they have loaded, a USB drive will have been created. Open Windows Explorer and you will be able to view the USB stick contents.

4.3 Node Finder Application

4.3.1 Introduction

Our devices are shipped to you with the IP DHCP setting enabled. This means that if the AEON Transmitter is connected to a network which is administered by a DHCP server, the IP address will be automatically allocated to it.

Node Finder can be used to identify a device IP address, or disable DHCP if you are not connected through a DHCP server or using a standalone PC or laptop.

If you are unsure about your server settings, check with your network administrator.

Note: If you are using a standalone PC or laptop, you will also need to set the IP address of the PC. Refer to *Section 10.1* to find out how to do this.

If the DTC device is connected to a network which does **not** have a DHCP server, contact your network administrator for an IP address you can use.

4.3.2 Install Node Finder on your PC

1. Double click the **NodeFinder.exe** file from the USB drive on your PC.
2. The **Node Finder Setup** window opens.

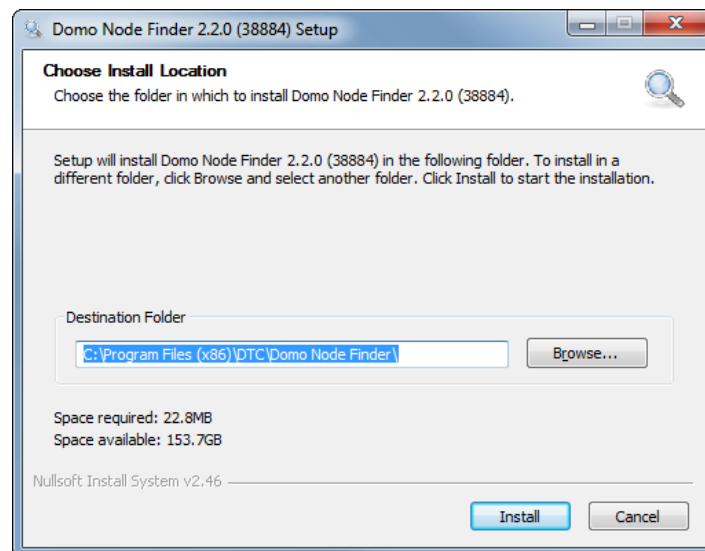

3. **Browse** to the location where you wish to install the software or leave the **Destination Folder** at default (recommended).
4. Click the **Install** button.
5. On completion **Close** the installer. A Node Finder icon will appear on your desktop.

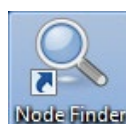

4.3.3 Establish the AEON Transmitter's IP Address using Node Finder

1. Power up the AEON Transmitter using one of the methods explained above.
2. Double click the newly installed Node Finder icon from your PC desktop.
3. Find the AEON Transmitter IP address from the Node Finder list.

Note: If the device is not connected to a network with a DHCP server, the IP address may appear as 0.0.0.0.

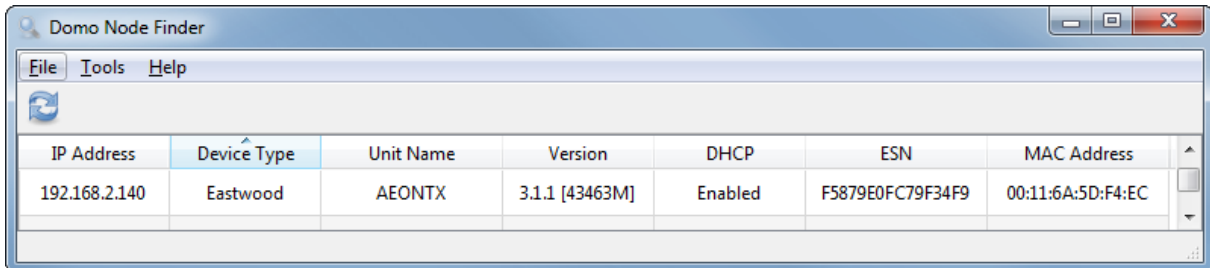

IP Address	Device Type	Unit Name	Version	DHCP	ESN	MAC Address
192.168.2.140	Eastwood	AEONTX	3.1.1 [43463M]	Enabled	F5879E0FC79F34F9	00:11:6A:5D:F4:EC

4. Right click on the IP address and select **Configure Network** to disable DHCP and set a fixed IP address, if required. The **IP Address** should be on the same address range as the network or standalone PC, the **Subnet Mask** should be left at 255.255.255.0 and the **Default Gateway** can be 0.0.0.0.

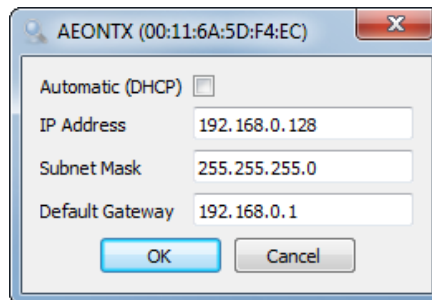

4.4 AEON Transmitter Web Browser Control

Now the IP address has been established, you can use a web browser to configure and monitor the AEON Transmitter.

Note: Although all web browsers may work with AEON devices, some operations cannot be guaranteed. DTC strongly recommend the use of Google Chrome.

1. Open a web browser and enter the IP address of the AEON device in the address bar.
2. An authentication required dialogue box will open.

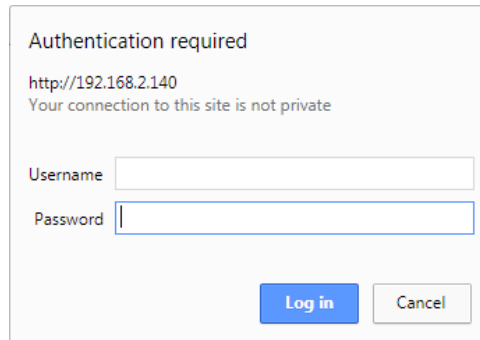

Authentication required

http://192.168.2.140
Your connection to this site is not private

Username

Password

3. The Password is **aeonweb** which is case sensitive. The Username should be left blank
4. Click **Log in**, the web browser control application opens.

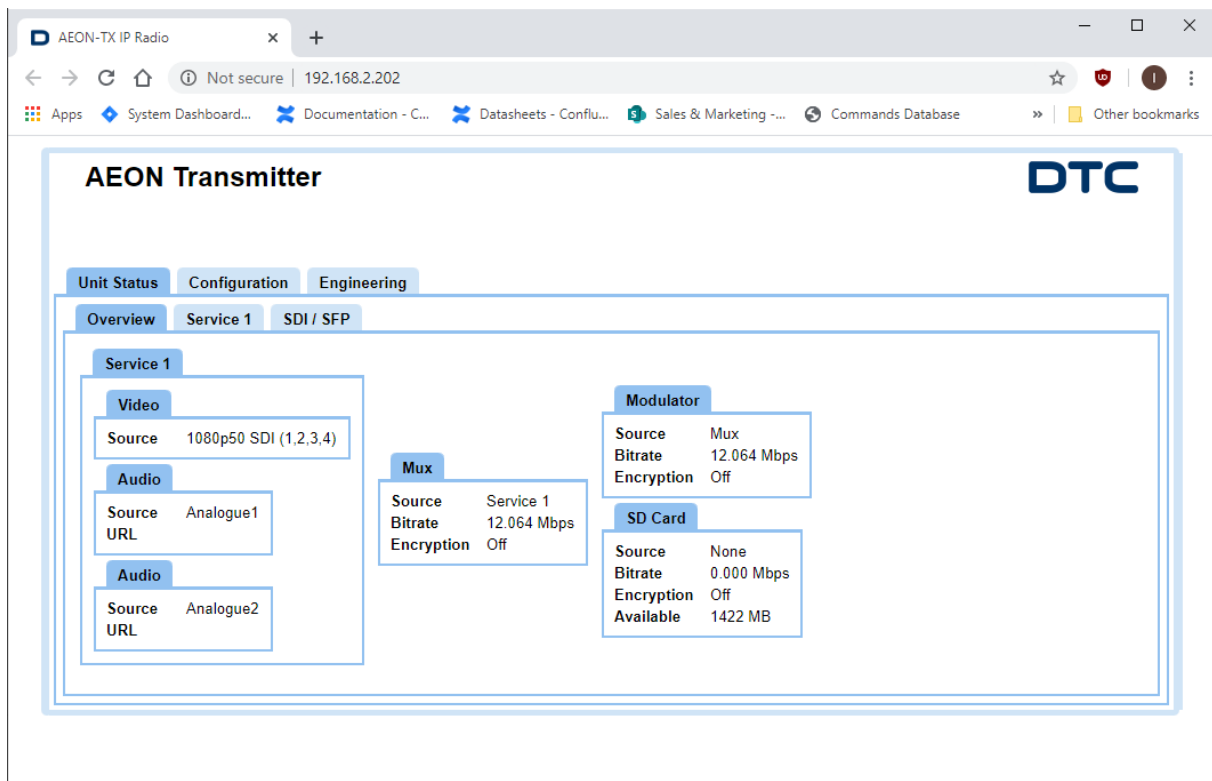

The screenshot shows a web browser window titled "AEON-TX IP Radio" with the address bar displaying "192.168.2.202". The browser's address bar shows "Not secure" and "192.168.2.202". The browser's bookmark bar shows "Apps", "System Dashboard...", "Documentation - C...", "Datasheets - Conflu...", "Sales & Marketing -...", "Commands Database", and "Other bookmarks".

The main content area displays the "AEON Transmitter" interface with the DTC logo in the top right corner. The interface has a navigation menu with "Unit Status", "Configuration", and "Engineering". Under "Configuration", there are sub-tabs for "Overview", "Service 1", and "SDI / SFP". The "Service 1" sub-tab is active, showing a "Service 1" section with three sub-sections: "Video", "Audio", and "Audio".

The "Video" sub-section shows "Source" as "1080p50 SDI (1,2,3,4)".

The "Audio" sub-section shows "Source" as "Analogue1".

The "Audio" sub-section shows "Source" as "Analogue2".

The "Mux" sub-section shows "Source" as "Service 1", "Bitrate" as "12.064 Mbps", and "Encryption" as "Off".

The "Modulator" sub-section shows "Source" as "Mux", "Bitrate" as "12.064 Mbps", and "Encryption" as "Off".

The "SD Card" sub-section shows "Source" as "None", "Bitrate" as "0.000 Mbps", "Encryption" as "Off", and "Available" as "1422 MB".

4.5 Web Browser Control

The web browser display options will change depending on the modes that are set. The chapters that follow will explain the differences where applicable:

- *AEON Transmitter Web Browser Operation – Chapter 5*
- *AEON-MESH Web Browser Operation – Chapter 6*

4.6 LCD/OLED Display Control

The AEON Transmitter and Decoder can be operated from an integral LCD/OLED display.

For details on LCD display control for the Transmitter refer to *Chapter 7*, and for Decoder OLED display refer to *Chapter 8*.

5. AEON Transmitter Web Browser Operation

5.1 Introduction

AEON Transmitters can be controlled from a **web browser** application via an Ethernet to setup pre-deployment configurations.

Note: Although all web browsers will work with AEON Transmitter, some operations cannot be guaranteed. DTC strongly recommend the use of **Google Chrome**.

This chapter explains the web browser operation, explaining each parameter. It will help you understand how to operate the AEON Transmitter to optimise performance.

5.2 Unit Status>Overview Tab

The Overview tab provides status information. The displayed information may depend on what functions have been enabled.

Streaming URLs can be copied into a media player.

The screenshot shows the AEON Transmitter web browser interface. The main heading is "AEON Transmitter" with the DTC logo in the top right. Below the heading are three tabs: "Unit Status", "Configuration", and "Engineering". Under "Unit Status", there are three sub-tabs: "Overview", "Service 1", and "SDI / SFP". The "Overview" tab is selected, and it shows a "Service 1" section with several sub-sections:

- Video:**
 - Source: 1080p50 SDI (1,2,3,4)
 - AV: <rtsp://10.183.2.79/av1.sdp>
 - ES: <rtsp://10.183.2.79/video1.sdp>
- Audio:**
 - Source: Analogue2
 - URL:
- Audio:**
 - Source: Analogue1
 - URL:
- Mux:**
 - Source: Service 1
 - Bitrate: 12.064 Mbps
 - Encryption: Off
 - TS: <rtsp://10.183.2.79/stream.sdp>
- Modulator:**
 - Source: Mux
 - Bitrate: 12.064 Mbps
 - Encryption: Off
- SD Card:**
 - Source: None
 - Bitrate: 0.000 Mbps
 - Encryption: Off
 - Available: 1422 MB

5.3 Unit Status>Service Tab

The Service tab provides video status information.

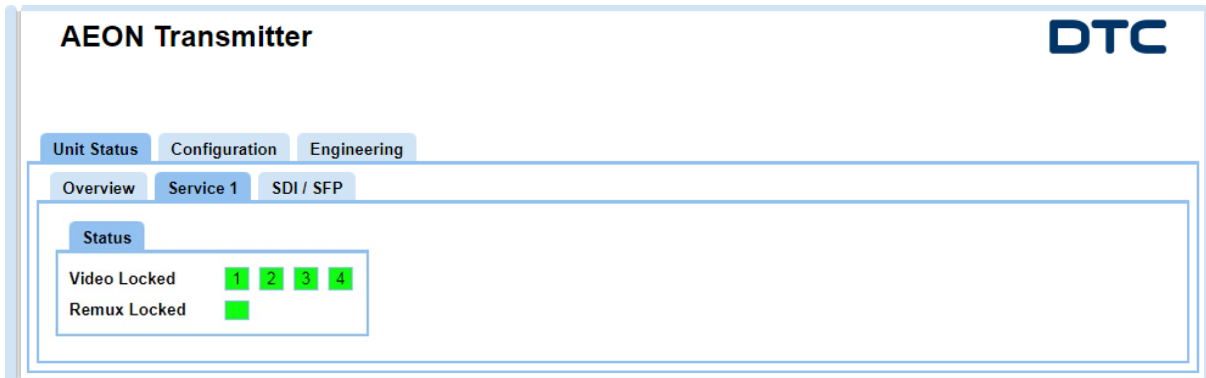

Property	Description
Status	<ul style="list-style-type: none"> ■ White – not configured ■ Red – not locked to source ■ Green – locked to source

5.4 Unit Status>SDI/SFP Tab

The SDI/SFP tab provides an overview of the gearing of the video inputs to outputs.

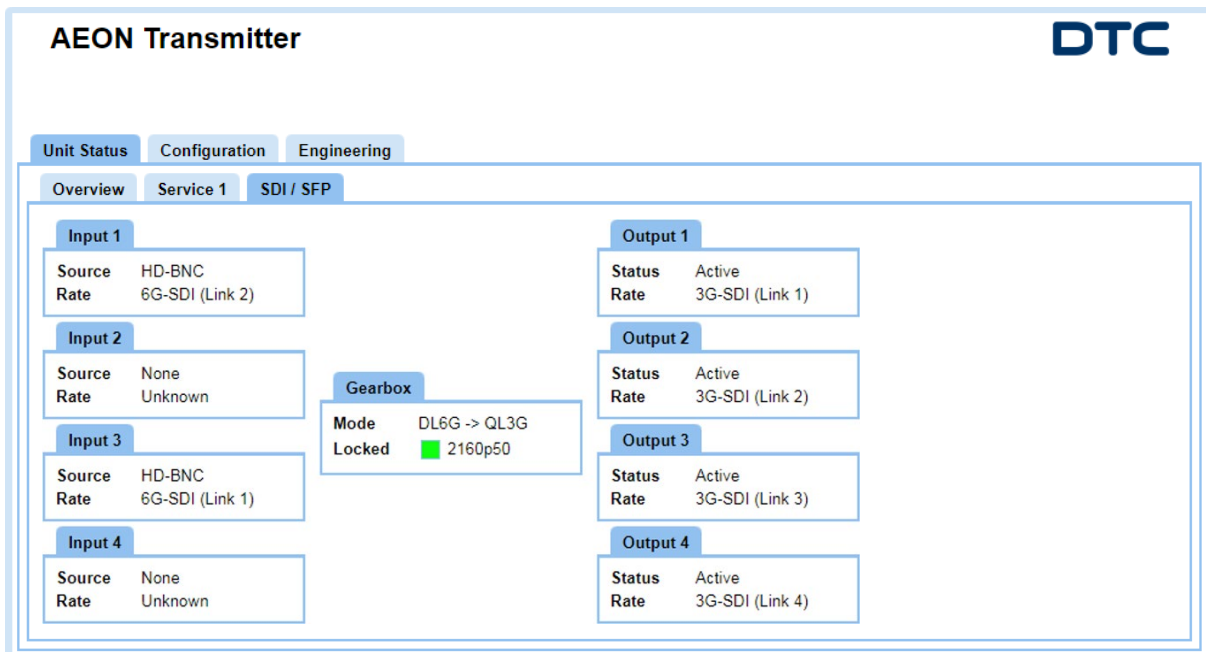

5.5 Configuration Tab – Apply, Save and Refresh

The **Global** and **Configuration** tabs use the **Apply**, **Save** and **Refresh** buttons. It is useful to know the differences and important to remember to click Apply or Save when any changes are made.

5.5.1 Apply

Click **Apply** to save the changes you have made and make the selected configuration active. The green highlighted box will show which preset configuration is active.

5.5.2 Save

Changes can be made to non-active configurations by clicking **Save**.

5.5.3 Refresh

If changes are made to parameters but applied or saved, click the **Refresh** button to return the screen to the current settings.

5.6 Configuration>Global Tab

Global parameters will make changes that will affect all global and preset settings.

If a 4G or Wi-Fi dongle is attached into the USB port, additional parameters will appear.

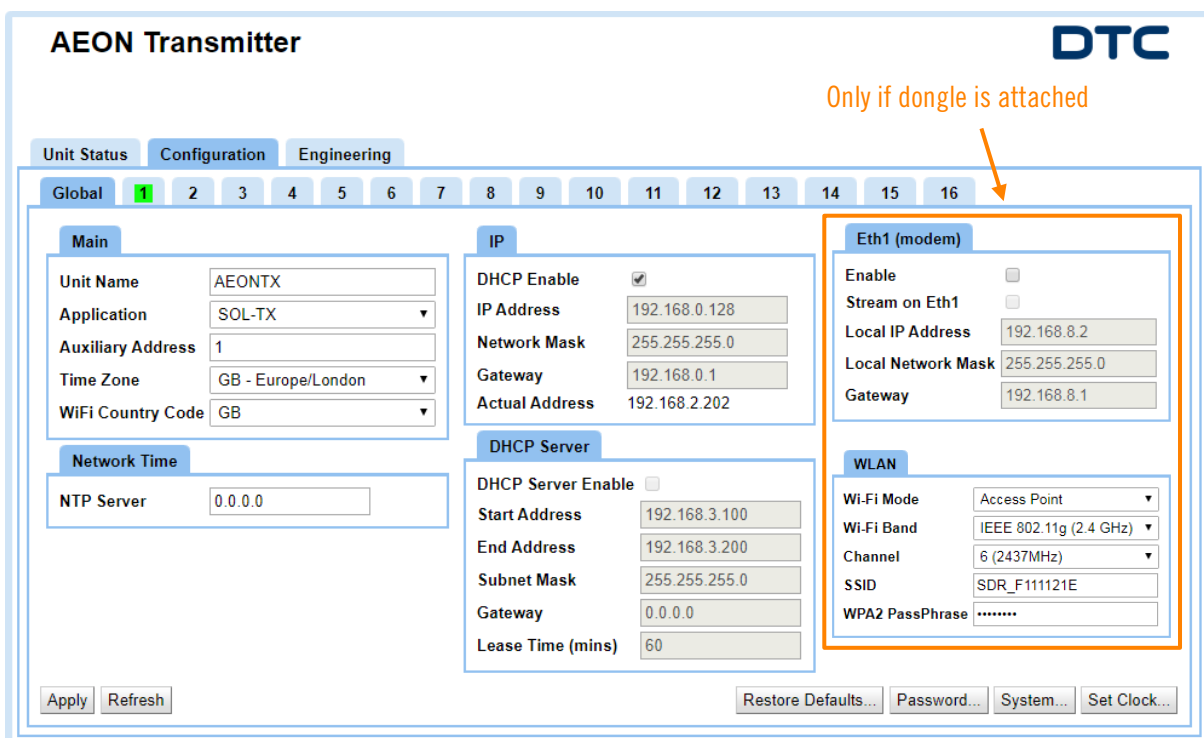

AEON Transmitter **DTC**

Unit Status Configuration Engineering

Global **1** 2 3 4 5 6 7 8 9 10 11 12 13 14 15 16

Main

Unit Name: AEONTX
 Application: SOL-TX
 Auxiliary Address: 1
 Time Zone: GB - Europe/London
 WiFi Country Code: GB

Network Time

NTP Server: 0.0.0.0

IP

DHCP Enable:
 IP Address: 192.168.0.128
 Network Mask: 255.255.255.0
 Gateway: 192.168.0.1
 Actual Address: 192.168.2.202

DHCP Server

DHCP Server Enable:
 Start Address: 192.168.3.100
 End Address: 192.168.3.200
 Subnet Mask: 255.255.255.0
 Gateway: 0.0.0.0
 Lease Time (mins): 60

Eth1 (modem)

Enable:
 Stream on Eth1:
 Local IP Address: 192.168.8.2
 Local Network Mask: 255.255.255.0
 Gateway: 192.168.8.1

WLAN

Wi-Fi Mode: Access Point
 Wi-Fi Band: IEEE 802.11g (2.4 GHz)
 Channel: 6 (2437MHz)
 SSID: SDR_F111121E
 WPA2 PassPhrase:

Apply Refresh Restore Defaults... Password... System... Set Clock...

Only if dongle is attached

5.6.1 Main Settings

Main

Unit Name	<input type="text" value="AEONTX"/>
Application	<input type="text" value="SOL-TX"/>
Auxiliary Address	<input type="text" value="1"/>
Time Zone	<input type="text" value="GB - Europe/London"/>
WiFi Country Code	<input type="text" value="GB"/>

Property	Value	Description
Unit Name	User defined	The unit name will identify your AEON Transmitter.
Application	MESH SOL-TX	<p>You can use this field to change the application of the AEON Transmitter if it has both license applications applied.</p> <p>When in SOL-TX mode, the unit RF ports are transmit only.</p> <p>When in MESH mode, the unit RF ports A and B become transceivers. The device can be combined in a fluid self-healing Mesh network containing up to 16 nodes.</p> <p>Note: Refer to <i>Chapter 6</i> for a brief AEON-Mesh overview. For detailed MESH user instructions you will have to refer to <i>NETNode Phase 5 Software User Guide</i>.</p>
Auxiliary Address	Default 1	This sets the address to which control commands will be written to. It may be of value to integrators who need to send commands to the AEON-TX or connected device.
Time Zone	ISO 3166-1 Alpha-2 code	<p>Select the country code for the time zone that you are in. This will be displayed on the OSD, if selected.</p> <p>No selection will default to UTC time.</p>
WiFi Country Code	ISO 3166-1 Alpha-2 code	If you are using a Wi-Fi dongle, you will need to select the country code to assist with channel selection.

5.6.2 Network Time

Network Time

NTP Server	<input type="text" value="0.0.0.0"/>
------------	--------------------------------------

Enter a Network Time Protocol (NTP) server IP address for clock synchronization to UTC time.

The default address is 0.0.0.0, in this condition there is no clock synchronisation.

5.6.3 IP Settings

IP

DHCP Enable	<input checked="" type="checkbox"/>
IP Address	192.168.0.128
Network Mask	255.255.255.0
Gateway	192.168.0.1
Actual Address	192.168.2.209

Our devices are shipped to you with the DHCP setting enabled. This means that if the AEON Transmitter is connected to a network which is administered by a DHCP server, an IP address will be automatically allocated to it.

If you are unsure about your server settings, check with your network administrator.

Note: If you are using a standalone PC or laptop, you will need to disable DHCP and set the IP address of the PC. Refer to *Appendix A – Reference Material* to find out how to do this.

The following table details the IP settings of the Global tab.

Parameter	Description
DHCP Enable	If selected, a DHCP server on the network will allocate an IP address.
IP Address	If DHCP is disabled, a fixed IP address needs to be assigned to the unit You may need to check with your network administrator for an IP address you can use.
Network Mask	This is usually defined by the network administrator. The network mask allows a network administrator to divide a network into smaller more efficient subnets to stop large numbers of IP packets being routed through the network.
Gateway	A default gateway is used by a host when an IP packet's destination address belongs outside the local subnet. The default gateway address is usually an interface belonging to the LAN's border router.
Actual Address	This is the actual IP address that is allocated to the AEON Transmitter by the DHCP server or if set manually.

5.6.4 DHCP Server Settings

DHCP Server

DHCP Server Enable	<input type="checkbox"/>
Start Address	<input style="width: 100%;" type="text" value="192.168.3.100"/>
End Address	<input style="width: 100%;" type="text" value="192.168.3.200"/>
Subnet Mask	<input style="width: 100%;" type="text" value="255.255.255.0"/>
Gateway	<input style="width: 100%;" type="text" value="0.0.0.0"/>
Lease Time (mins)	<input style="width: 100%;" type="text" value="60"/>

Property	Description
DHCP Server Enable	If this box is set, the AEON transmitter will act as a DHCP server. This setting will be greyed out if the IP setting for DHCP Enable is set, <i>Section 5.6.3</i> .
Start Address End Address	The DHCP address range.
Subnet Mask	The subnet mask divides a network into smaller more efficient subnets to stop large numbers of IP packets being routed through the network.
Gateway	A gateway is used by a host when an IP packet's destination address belongs outside the local subnet.
Lease Time	The length of time an IP address is reserved for a device. <div style="border: 1px solid #0070C0; padding: 2px; margin-top: 5px;">Note: To ensure the DHCP address pool remains available, either increase the address range or decrease the lease time.</div>

5.6.5 Eth (modem) Settings

Eth1 (modem)

Enable	<input type="checkbox"/>
Stream on Eth1	<input type="checkbox"/>
Local IP Address	<input style="width: 100%;" type="text" value="192.168.8.2"/>
Local Network Mask	<input style="width: 100%;" type="text" value="255.255.255.0"/>
Gateway	<input style="width: 100%;" type="text" value="192.168.8.1"/>

When a 4G LTE USB Dongle is inserted in the USB port, **Eth1 (modem)** parameters will appear.

4G dongles that are currently supported are:

- Verizon MiFi USB620L 4G (USA)
- E3372s-153 (pid 157d)
- E3372h-153 (pid 1f01)

Parameter	Description
Enable	When this is set, this will allow you to edit the IP settings.
Stream on Eth1	When this is set, this will allow you to stream over a 4G LTE network.
Local IP Address	This is the IP address of the 4G LTE dongle.
Local Network Mask	This is the network mask of the 4G LTE dongle.
Gateway	This is the gateway address for the 4G LTE dongle.

Note: When you stream using the 4G dongle you will need to configure the Streamer settings accordingly.

5.6.6 WLAN Settings

WLAN

Wi-Fi Mode: Access Point ▼

Wi-Fi Band: IEEE 802.11g (2.4 GHz) ▼

Channel: 6 (2437MHz) ▼

SSID: SDR_F111121E

WPA2 PassPhrase:

When a Wi-Fi USB dongle is inserted into the USB port, **WLAN** parameters will appear.

Wi-Fi dongles that are currently supported are:

- TP-LINK AC1300
- TP-LINK AC1200

Parameter	Description
Wi-Fi Mode	Set to Access Point to allow the AEON-TX to connect to other Wi-Fi enabled devices.
Wi-Fi Band	Set the Wi-Fi Band for the system.
Channel	Channels 1, 6 and 11 are primary Wi-Fi channels. The others are available but can crossover with other channels and cause interference. Ensure the correct Country Code has been selected in the Main settings.
SSID	A Service Set Identifier (SSID) is the public name for the wireless network.
WPA2 PassPhrase	Set the access point password.

5.6.7 Restore Defaults Button Restore Defaults...

If you click on the **Restore Defaults** button a dialog box opens:

Restore Defaults

Restore Configs

Restore Globals

Restore All

Cancel

- **Restore Configs** – restores the sixteen configurations to factory default conditions
- **Restore Globals** – restores the Global settings to factory default conditions
- **Restore All** – restores Global settings and all configurations to factory default conditions

5.6.8 Password Button

The Password button allows you to change the password for the AEON Transmitter. If you click on it, the Change Password dialogue box opens:

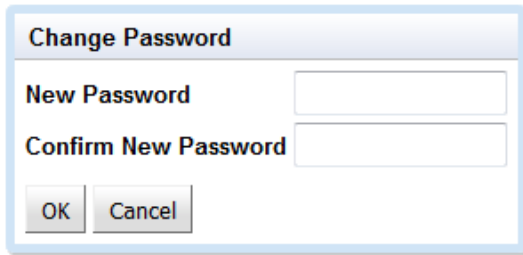

The 'Change Password' dialog box features a title bar with the text 'Change Password'. Below the title bar, there are two text input fields: the first is labeled 'New Password' and the second is labeled 'Confirm New Password'. At the bottom of the dialog box, there are two buttons: 'OK' and 'Cancel'.

5.6.9 System Button

The AEON Transmitter has an SD card which allows the user to store recordings. If you click on the System button, a dialogue box opens:

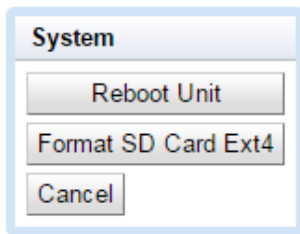

The 'System' dialog box has a title bar with the text 'System'. It contains three buttons: 'Reboot Unit', 'Format SD Card Ext4', and 'Cancel'.

- **Reboot Unit** – will force a reboot of the AEON Transmitter
- **Format SD Card Ext4** – will format your SD card in the file system used by Linux.

CAUTION: When you format an SD card it will delete all contents.

5.6.10 Set Clock Button

Click on the Set Clock button to set the date and time to UTC time.

5.7 Configuration>Unit Tab

There are up to sixteen different preset **Configurations** that can be setup. In this example we are viewing preset **1** which is highlighted with a green background to denote that it is active.

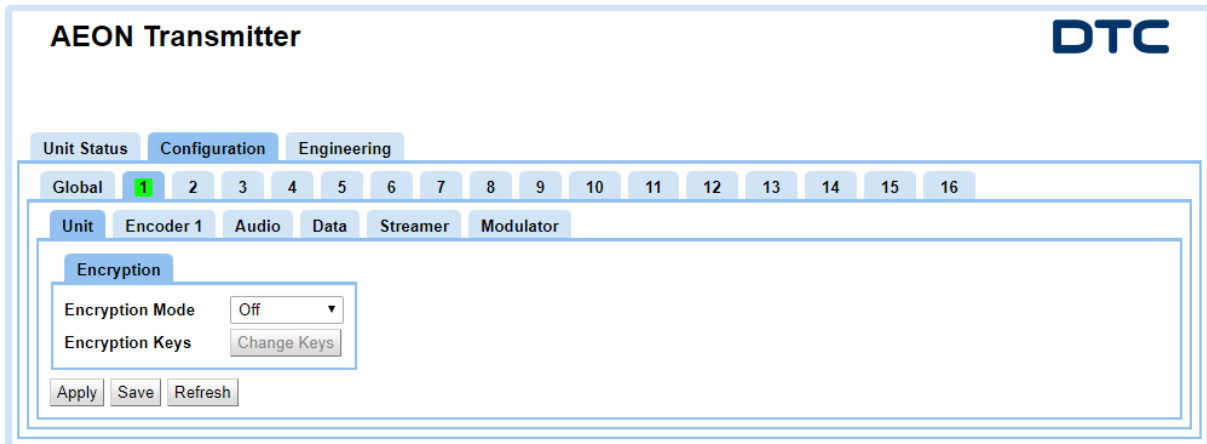

It may be very important to scramble video and audio before they are passed across networks.

Note: Encryption modes except ABS are licensed. If there is an encryption mode you want but does not appear in the list, please contact DTC.

Property	Value	Description
Encryption Mode	Off ABS AES128, AES256 CCrypt, CCrypt256	Click on the box and select your encryption mode from the dropdown list. The options will be license dependent. Note: CCrypt encryption are included with the AES encryption license.
Encryption Keys	<input type="button" value="Change Keys"/>	If you click on this button the Scrambling Key dialogue box will open. Enter the encryption key for your system. When you click OK remember you will still need to click Apply to activate the encryption.

5.8 Configuration > Encoder Tab

There are up to sixteen different preset **Configurations** that can be setup. In this example we are viewing preset **1** which is highlighted with a green background to denote that it is active.

The screenshot shows the 'AEON Transmitter' interface with the 'Configuration' tab selected. Under 'Configuration', 'Encoder 1' is the active preset. The 'Encoder' settings are as follows:

Property	Value
Video Source	SDI (1,2,3,4)
Video Format	1080p
Video Rate	50
Chroma Format	4:2:2
Bit Depth	10-bit
Encoder Mode	Ultra low delay
Compression	MPEG2
QuadSync	Off

Property	Value	Description
Video Source	SDI (1,2,3,4)	Select the video input source
Video Format	480i, 576i, 480p, 576p, 720p, 1080i, 1080p 1080psf 2SI 2160p SQD 2160p	Select the video format.
Video Rate	23.976, 24, 25, 29.97, 30, 50, 59.94, 60	Select the video frame rate.
Chroma Format	4:2:0 4:2:2	Select the level of chroma sampling required.
Bit Depth	8-bit 10-bit	Select the number of bits per pixel.
Encoder Mode	Normal delay Low delay Ultra low delay	Select the level of delay. Normal delay provides higher picture quality at the expense of delay. Low Delay provides very low delay at the expense of picture quality.

Property	Value	Description
Compression	HEVC AVC MPEG2	When the AEON Transmitter Encoder Config is set to AEON Single in the Unit tab, the encoding mode will always be HEVC.
QuadSync	Off On	When encoding 4 x 3G-SDI inputs in 4K video format, it is advisable to set QuadSync to On .

5.9 Configuration>Audio Tab

There are up to sixteen different preset **Configurations** that can be setup. In this example we are viewing preset **1** which is highlighted with a green background to denote that it is active.

AEON Transmitter DTC

Unit Status **Configuration** Engineering

Global **1** 2 3 4 5 6 7 8 9 10 11 12 13 14 15 16

Unit Encoder 1 **Audio** Data Streamer Modulator

Analogue Audio 1 **Analogue Audio 2**

	Left	Right	
Analogue Gain	0.0	0.0	dB
Phantom Power	<input type="checkbox"/>	<input type="checkbox"/>	

	Left	Right	
Analogue Gain	0.0	0.0	dB
Phantom Power	<input type="checkbox"/>	<input type="checkbox"/>	

	Audio Source	Audio Mode
Audio 1	Analogue1	LPCM(16bit)
Audio 2	Analogue2	AAC
Audio 3	SDI 1 (G2P1)	MPEG L1
Audio 4	SDI 1 (G2P2)	MPEG L2
Audio 5	SDI 1 (G1P2)	LPCM(20bit)
Audio 6	SDI 2 (G1P2)	LPCM(24bit)
Audio 7	SDI 3 (G1P2)	LPCM(16bit)
Audio 8	SDI 4 (G1P2)	MPEG L1

Apply Save Refresh

5.9.1 Analogue Audio

Analogue Audio 1

	Left	Right	
Analogue Gain	<input type="text" value="0.0"/>	<input type="text" value="0.0"/>	dB
Phantom Power	<input type="checkbox"/>	<input type="checkbox"/>	

Property	Value	Description
Analogue Gain	Up to 40dB	Gain can be applied at the left and right inputs if the source is at low level.
Phantom Power	Checkbox	When set, this will apply 48V phantom power to the microphone, if required.

5.9.2 Audio

	Audio Source	Audio Mode
Audio 1	Analogue1	AAC
Audio 2	Analogue2	MPEG L1
Audio 3	SDI 1 (G2P1)	AAC
Audio 4	SDI 1 (G2P2)	AAC
Audio 5	SDI 1 (G3P1)	MPEG L1
Audio 6	SDI 1 (G3P2)	MPEG L1
Audio 7	SDI 1 (G4P1)	Off
Audio 8	SDI 1 (G4P2)	Off

Property	Value	Description
Audio Source Audio 1	Analogue 1 SDI 1 (G1P1) Test Tone Analogue 2	When Analogue is selected, the input gain and phantom power can be edited, see Analogue Audio settings above. When an SDI input is selected, the audio is embedded in the SDI video signal.
Audio Source Audio 2	Analogue 1 SDI 1 (G1P2) Test Tone Analogue 2 SDI 2 (G1P1)	
Audio Source Audio 3	Analogue 1 SDI 1 (G2P1) Test Tone Analogue 2 SDI 3 (G1P1)	

Property	Value	Description
Audio Source Audio 4	Analogue 1 SDI 1 (G2P2) Test Tone Analogue 2 SDI 4 (G1P1)	
Audio Source Audio 5	Analogue 1 SDI 1 (G3P1) Test Tone Analogue 2 SDI 1 (G1P2)	
Audio Source Audio 6	Analogue 1 SDI 1 (G3P2) Test Tone Analogue 2 SDI 2 (G1P2)	
Audio Source Audio 7	Analogue 1 SDI 1 (G4P1) Test Tone Analogue 2 SDI 3 (G1P2)	
Audio Source Audio 8	Analogue 1 SDI 1 (G4P2) Test Tone Analogue 2 SDI 4 (G1P2)	
Audio Mode	Off LPCM(16bit) AAC MPEG L1 MPEG L2 LPCM(20bit) LPCM(24bit)	

Note: The Audio PIDs are listed in the PMT (see *Section 5.11.2*).

5.10 Configuration>Data Tab

There are up to sixteen different preset **Configurations** that can be setup. In this example we are viewing preset **1** which is highlighted with a green background to denote that it is active.

The screenshot shows the 'AEON Transmitter' configuration window. At the top right is the 'DTC' logo. Below the title bar are three main tabs: 'Unit Status', 'Configuration', and 'Engineering'. Under 'Configuration', there are 16 numbered tabs (Global, 1, 2, 3, 4, 5, 6, 7, 8, 9, 10, 11, 12, 13, 14, 15, 16). Tab '1' is highlighted in green. Below these are sub-tabs: 'Unit', 'Encoder 1', 'Audio', 'Data', 'Streamer', and 'Modulator'. The 'Data' sub-tab is active, showing a 'Data' section with 'Mode' set to 'RS-232' and 'Baud Rate' set to '1200'. Below that is an 'Ancillary' section with 'Extract Mode' set to 'Off'. At the bottom are 'Apply', 'Save', and 'Refresh' buttons.

5.10.1 Data Settings

Data

Mode: RS-232

Baud Rate: 1200

Property	Value	Description
Mode	Off RS232	Selects if RS232 data is to be sent over the link.
Baud Rate	1200 to 115200	This is the speed of serial data that is passed. It should match the data source capability.

5.10.2 Ancillary Settings

Ancillary

Extract Mode: All type 2

Property	Value	Description
Extract Mode	Off All type 2	Type 2 data can be extracted from the SDI inputs and packetized, if required. The data must be re-inserted into the SDI at the decoder.

5.11 Configuration > Streamer

There are up to sixteen different preset **Configurations** that can be setup. In this example we are viewing preset **1** which is highlighted with a green background to denote that it is active.

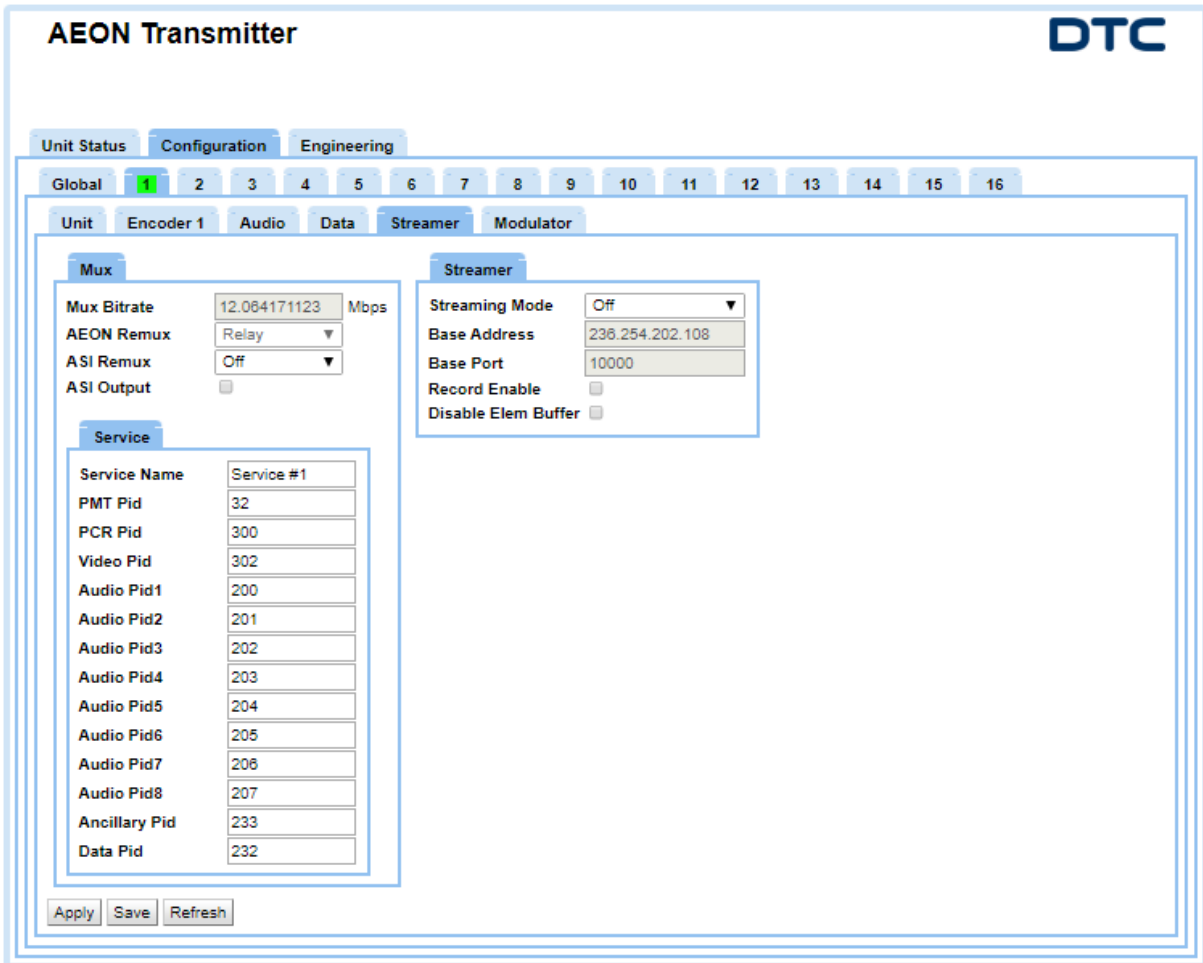

5.11.1 Mux Settings

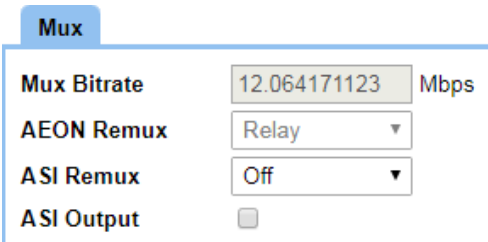

Property	Value	Description
Mux Bitrate	Up to 50Mbps/s	The multiplexer bitrate for the service. If the Modulation is set to Off in the Modulator tab, this can be set manually.
AEON Remux	Relay	Set by default to Relay mode. This means that only services encoded by the AON Transmitter can be streamed.

Property	Value	Description
ASI Remux	Off On Relay	Off – No ASI On – Enables the re-multiplexing of an ASI input Relay – disables local services and only passes ASI.
ASI Output	Checkbox	When set, the ASI output will contain the same content sent over the modulator.

Note 1: The mux bitrate must be equal to or greater than the total bit rate of services and inputs. If the total bit rate exceeds the mux bitrate the output stream will not work.

Note 2: If you set ASI Remux to Relay it disables the video source for that channel. You must switch ASI Remux Off when you want to reselect a video source.

5.11.2 Service Settings

Service	
Service Name	Service #1
PMT Pid	32
PCR Pid	300
Video Pid	302
Audio Pid1	200
Audio Pid2	201
Audio Pid3	202
Audio Pid4	203
Audio Pid5	204
Audio Pid6	205
Audio Pid7	206
Audio Pid8	207
Ancillary Pid	233
Data Pid	232

Note: The PID values can be edited but should be left to default unless an advanced user. PID values can be changed from 32 to 8190.

Property	Description
Service Name	An identifier for the service in the Transport Stream (TS). The TS can have many services. The receiver must align with this name for the service to be decoded.
PMT Pid	This sets the packet id for the Program Map Table. For each Program, there is one PMT.
PCR Pid	This sets the packet id for the Program Clock Reference which is used to sync the audio and video. The PCR PID is listed in the PMT.

Property	Description
Video Pid	This sets the packet id for the video content in the Program. The Video PID is listed in the PMT.
Audio Pid1-8	This sets the packet id for the audio content in the Program. The Audio PID is listed in the PMT.
Data Pid	This sets the packet id for the data content in the Program. The Data PID is listed in the PMT.

5.11.3 Streamer Settings

Streamer

Streaming Mode	<input type="text" value="UDP"/>
Base Address	<input type="text" value="236.254.202.108"/>
Base Port	<input type="text" value="10000"/>
Record Enable	<input type="checkbox"/>
Disable Elem Buffer	<input type="checkbox"/>

Property	Value	Description
Streaming Mode	Off UDP RTSP TCP RTSP UDP RTSP Multicast RTP RTP-Z	<p>RTSP TCP and RTSP UDP are both unicast.</p> <p>RTSP TCP streaming does not have issues with firewall blocking making it more user friendly for VMS customers.</p> <div style="border: 1px solid #00aaff; padding: 2px; margin: 5px 0;"> <p>Note: RTP-Z is DTC's compressed RTP. You will need Domo Video Player to run streams using this protocol.</p> </div> <p>URLs can be found in the Unit Status>Overview tab.</p>
Base Address	User defined	<p>This enables you to change the address used by the unit for streaming.</p> <p>The default value is random to make sure different transmitters have different multicast addresses.</p>
Base Port	10000 or above	<p>Port numbers in the header are used to direct traffic around the network. A good rule is to use numbers above 10000 to avoid conflict with existing services.</p> <p>When you set up a port number on several computers on a network, they will all listen for packets directed to that port.</p>

Property	Value	Description
Record Enable	Checkbox	<p>When you set this box, the video will be recorded to the built in SD card.</p> <p>Recordings can be downloaded using the Domo Video Download Tool available on WatchDox, see <i>Section 11.1</i>.</p> <p>To playback to a media player without downloading, set the Streaming Mode to RTSP and use the format:</p> <pre>rtsp://<ip_address>/play.sdp</pre>
Disable Elem Buffer	Checkbox	<p>If set, this will ensure correct timing of video frames for elementary streams. When disabled the rate is kept constant within the transport stream.</p> <p>Might be useful to enable when playing elementary streams into media players.</p> <p>Disable to prevent a Mesh network becoming overloaded with data.</p>

5.12 Configuration > Modulator Tab

There are up to sixteen different preset **Configurations** that can be setup. In this example we are viewing preset **1** which is highlighted with a green background to denote that it is active.

5.12.1 Mod Settings

Property	Value	Description
Modulation Mode	None DVB-T NB/UMVL	When you set this, the adjacent settings will change accordingly for DVB-T or NB/UMVL.
Modulation On	Checkbox	Sets the RF output On or Off.
Frequency	Determined by unit variant.	Type in the frequency you wish to use for the system. This must be the same on the receiver. When you use a frequency in the primary COFDM band, RF ports A and B are active. When you use a frequency in the secondary frequency band, RF port C becomes active. Note: The primary and secondary frequency bands are defined by the transmitter variant. See <i>Section 2.6</i> .

Property	Value	Description
Output Attenuation	0 to 32	Attenuation can be applied to reduce the output power.
RF Output Port	A B A+B C	<p>The transmitter has three COFDM antennas, A, B and C.</p> <p>When transmitting in the primary COFDM band, B is selected as the output antenna by default, but you can select A or A+B if required.</p> <p>When transmitting in the secondary COFDM band, C will be selected automatically and greyed out.</p>
PA Linearity	High Low	<p>High linearity improves COFDM shoulder performance at the expense of power consumption.</p> <p>Usually used when working with power amplifiers which must have excellent shoulder performance, or for improved adjacent channel performance.</p>

5.12.2 DVB-T or NB/UMVL Settings

Note: The properties will change depending on the **Modulation Mode** selected. Some of the options may not be available for the selected Mode.

DVB-T Settings	NB/UMVL Settings
Bandwidth: 8 MHz ▼	Bandwidth: 2.5 MHz ▼
Constellation: 16-QAM ▼	Constellation: QPSK ▼
FEC Rate: 1/2 ▼	FEC Rate: 2/3 ▼
Guard Interval: 1/32 ▼	Guard Interval: 1/16 ▼
Dual Pedestal: Off ▼	Spectrum Inversion: <input type="checkbox"/>
Spectrum Inversion: <input type="checkbox"/>	

Property	Value	Description
Bandwidth	625kHz 1.25MHz 2.5MHz 6MHz 7MHz 8MHz	<p>DVB-T modes give excellent data throughput but shorter range than Narrowband modes.</p> <p>Narrowband modes give excellent range and best use of available channel bandwidth.</p> <p>Ultra Mobile Video Link modes give higher data throughput than Narrowband by using the same bandwidths as DVB-T. UMVL will give an advantage over DVB-T at C/X-band in short range mobile environments.</p>
Constellation	QPSK 16-QAM 64-QAM BPSK 8-PSK	<p>The COFDM constellation in use.</p> <p>QPSK, BPSK and 8-PSK - less user data, more robust, more range.</p> <p>16QAM - more user data, less robust, less range (link performance reduced by 5db).</p> <p>64QAM - max user data, least robust, least range.</p>
FEC Rate	1/2 1/3 2/3 3/4 5/6 7/8	<p>The forward error correction (FEC) rate.</p> <p>1/2 means 1 bit out of 2 bits is data and thus 1 bit is used for error correction.</p> <p>7/8 means 7 bits out of 8 bits are data and thus 1 bit is used for error correction.</p> <p>More user data means better picture quality, but less error correction means less robust signal and thus less range.</p>
Guard Interval	1/32 1/16 1/8 1/4	<p>The guard interval is an extension of the RF symbol period to give immunity to reflections.</p> <p>1/32 deals with fast reflections, more data, less range.</p> <p>1/4 deals with slower reflections, less data, more range.</p>

Property	Value	Description
Dual Pedestal	Off Single Port Dual Port	<p>Only available in DVB-T. Dual Pedestal mode will double the bitrate by using two adjacent COFDM channels with an approximate 1.5MHz separation. i.e. DVB-T 8MHz in dual pedestal mode will give a total bandwidth of 17.5MHz.</p> <p>See <i>Figure 5-1</i> and <i>Figure 5-2</i>.</p> <p>Single Port (A or B OR A+B) – 100mW output for both channels on a single port.</p> <p>Dual Port (A+B) – 100mW output for each channel on both ports (200mW total).</p> <p>Note: Dual port (A+B) will give the best adjacent channel performance at higher power but will produce more heat. Ensure sufficient cooling is provided.</p>
Spectrum Inversion	Checkbox	<p>Only set this if you need to invert the COFDM spectrum to align with third party equipment.</p> <p>When operating with DTC products leave clear.</p>

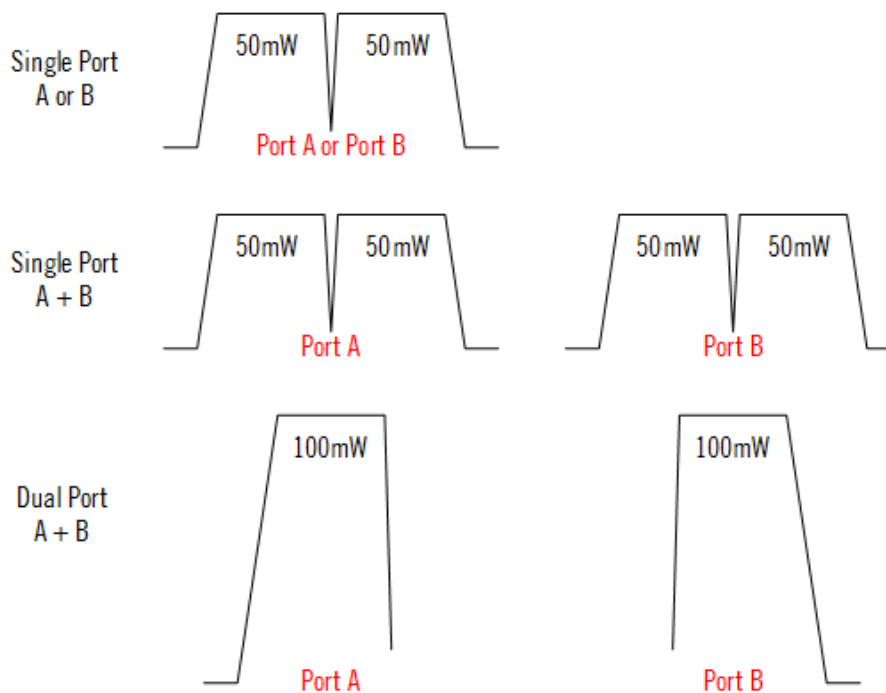

Figure 5-1 Dual Pedestal COFDM Representation

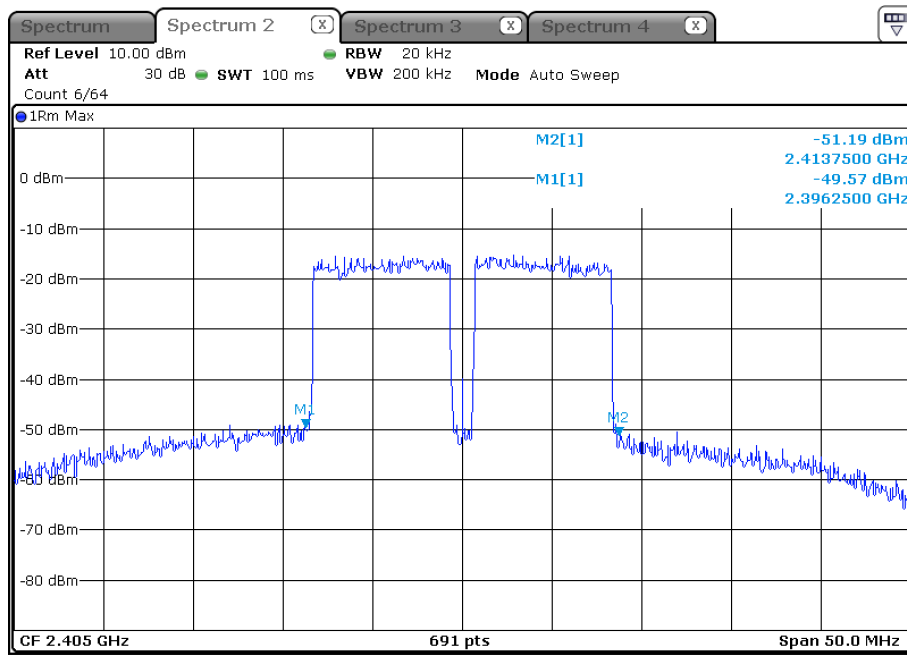

Figure 5-2 Dual Pedestal Spectrum Analyser Plot

5.13 Engineering>Information Tab

The **Information** tab provides software and licensing information that may be useful during a service call. It also gives voltage and temperature measurements of the internal PCBs for monitoring.

AEON Transmitter **DTC**

Unit Status | Configuration | **Engineering**

Information | Calibration | Uploads | Configs

Board Type	D750	Licensable Features	[A] SOLO 2.5MHz Modulation
SW Version	4.4.1		[B] SOLO 1.25MHz Modulation
SW Branch	/SDR/trunk		[C] SOLO 625kHz Modulation
SVN Revision	49119		[E] UMVL Modulation
Serial Number	68F2CD7AD6FECA6C		[F] DVB-T Modulation
MAC Address	00:11:6A:10:92:FB		[H] License Exempt Band Only
Licensed Codes	ABCEFJKMNRST6789045UVWXY		[6] 3G-SDI Route 1
Supply Voltage	12.1 V		[7] 3G-SDI Route 2
Battery Voltage	0.1 V		[8] 3G-SDI Route 3
Passthrough Trip	Yes		[9] 3G-SDI Route 4
FPGA Temperature	57.0 °C		[J] SD H.264 Encoder
HEVC Board Type	B110		[K] HD H.264 Encoder
HEVC SW Version	1.6		[M] AES128 Scrambling
HEVC Serial Number	CBE1D3B0		[N] AES256 Scrambling
HEVC Temperature	60.0 °C 63.0 °C		[R] Recording
HEVC License Mask	000203FD		[S] Streaming
	MPEG Layer 1		[T] Telemetry
	PSF		[0] Multi-Mesh
	Quad-Sync		[1] DES Mesh Scrambling
	10-bit		[2] AES128 Mesh Scrambling
	4:2:2		[3] AES256 Mesh Scrambling
	UHD		[4] SIMO Mesh
	Ultra Low Del		[5] MIMO Mesh
	MPEG2		[D] ACRX Mesh Mode
	H.264		[I] Interference Avoidance
	HEVC		[U] SOLO 2.5MHz Demodulation
	Decoder		[V] SOLO 1.25MHz Demodulation
	Encoder		[W] SOLO 625kHz Demodulation
			[X] UMVL Demodulation
			[Y] DVB-T Demodulation

Note: The **Passthrough Trip** parameter indicates overcurrent of the power to the camera plate and may indicate a fault. Reboot to clear. The above screenshot shows a fail.

5.14 Engineering>Calibration Tab

The Calibration tab is used to set the calibration values of the AEON Transmitter. They are password controlled and are used at DTC to configure RF performance prior to shipment.

AEON Transmitter **DTC**

Unit Status | Configuration | **Engineering**

Information | **Calibration** | Uploads | Configs

5.15 Engineering>Uploads

5.15.1 Overview

The Uploads tab lets you send software upgrade files or upload a license file to enable new features.

There are two software upgrade files for the AEON Transmitter – one for the **D750** board and one for the **B110 HEVC** board.

Haar Cascade XMLs are used feature detection when the AEON is in MESH application. Further details are provided in the *NETNode Software User Guide*.

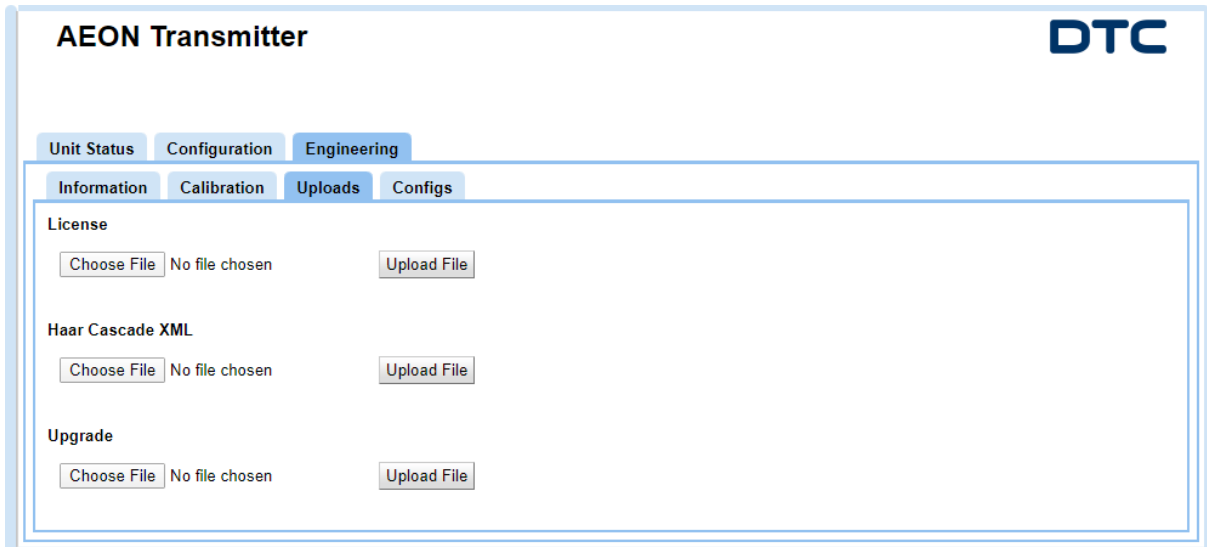

5.15.2 License Upgrade

If you have a new license file which needs to be uploaded to the AEON Transmitter, you will need to save it to a convenient location on your PC's file system.

On the AEON Transmitter web browser, go to the **Engineering>Uploads** tab and click on **Choose File** under the **License** heading.

License

No file chosen

Browse to the saved license file, select **Open** and click **Upload File** on the web browser.

Refresh the web browser and go to the **Engineering>Information** tab. Check that the new license features have been enabled.

5.15.3 D750/B110 Upgrade

If you have a D750 or B110 upgrade file which needs to be uploaded to the AEON Transmitter, you will need to save it to a convenient location on your PC's file system.

Note: The file name will contain the version, check the **Engineering>Information** tab to confirm the upgrade file is for a newer software version. The B110 upgrade takes 10 minutes, do not upgrade unless necessary.

On the AEON Transmitter web browser, go to the **Engineering>Uploads** tab and click on **Choose File** under the **Upgrade** heading.

Upgrade

Choose File No file chosen

Upload File

Browse to the saved license file, select **Open** and click **Upload File** on the web browser.

A dialogue box message will be displayed for a few minutes before the browser times out.

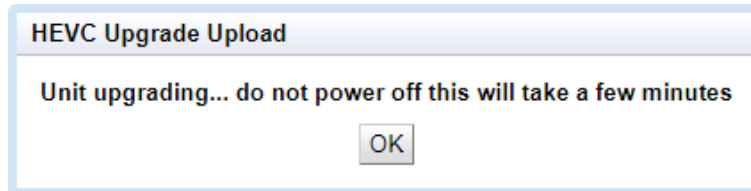

CAUTION: It is essential that the AEON Transmitter is **not** powered down at this stage, the D750 upgrade will be complete when the unit reboots. The B110 upgrade takes 10 minutes.

Note: The upgrade involves uploading the code to the on-board SD card which then writes the code to the flash. During the writing cycle, the unit will lose web browser control for several minutes depending on how many parts of the code need to be upgraded.

A useful way to observe this cycle is to open a command prompt (enter **cmd** in the Windows Start Menu search box) and enter a permanent ping command, the syntax for this is:

```
ping -t <AEON-TX_ip_address>    e.g. ping -t 192.168.2.133
```

The pings will reply for a while then time out (the write cycle). When the pings reply again, the AEON Transmitter will have rebooted and the upgrade is complete.

When the upgrade is complete, the web browser can be recovered. Refresh the web browser to view the new software version in the **Information** tab.

5.16 Engineering>Configs

The Configs tab provides an easy way to save (**Export Settings**) the sixteen preset configurations for upload to other AEON devices.

You can also upload (**Import Settings**) other pre-saved or edited configuration files, which will overwrite the current settings.

The file content is in JSON format. Full details of how to work with JSON files is provided in DTC's *JSON integration Document*.

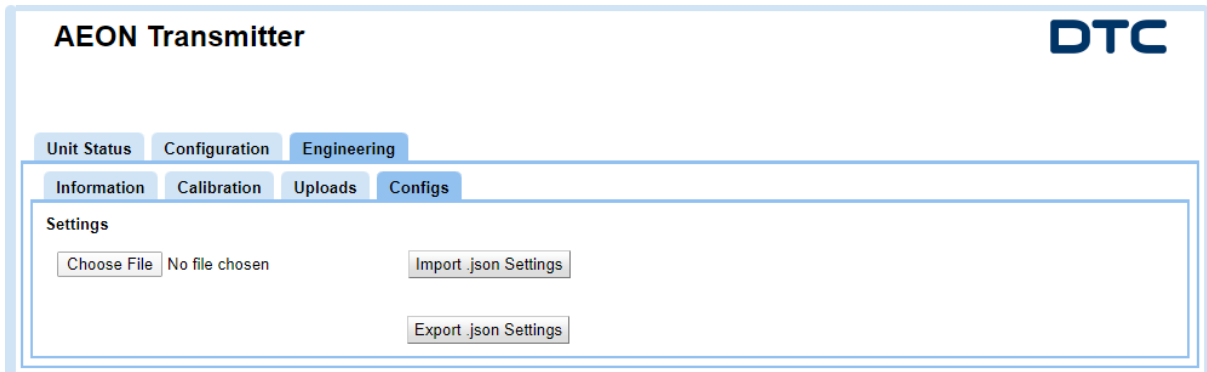

6. AEON-MESH Web Browser Operation

6.1 Introduction

Note: This chapter will only detail the configurations which are not detailed in the *NETNode Phase 5 Software Guide* or in previous chapters of this document.

For full details of Mesh operation, refer to DTC document *NETNode Phase 5 Software Guide* which has instructions which are compatible with the AEON-MESH.

When AEON-TX application is set to **MESH** in the **Configuration>Global** tab, some views and selections will change accordingly.

The screenshot displays the 'AEON Mesh IP Radio' web interface. The page title is 'AEON Mesh IP Radio' with the DTC logo in the top right. Below the title, it shows '9 - 10 - AEONTX - 2020MHz'. The interface has three main tabs: 'Unit Status', 'Configuration', and 'Engineering'. Under 'Configuration', there are 16 numbered sub-tabs, with 'Global' selected. The 'Main' section contains several configuration fields: 'Advanced Mode' (checkbox), 'Unit Name' (text: AEONTX), 'Application' (dropdown: MESH), 'Auxiliary Address' (text: 6), 'Time Zone' (dropdown: --), 'WiFi Country Code' (dropdown: 00), 'Speed Units' (dropdown: Knots), 'Logging Enable' (checkbox), and 'Update All Nodes*' (checkbox). The 'Network Time' section has 'Sync Local Time' (dropdown: Off/NTP) and 'NTP Server' (text: 0.0.0.0). The 'Telemetry' section shows 'Frequency' (text: 445 MHz), 'Training Freq' (text: 433.04998779 MHz), 'Mod Mode' (dropdown: 2-GFSK, 4800 baud), and 'Packet Status' (text: Undetermined LQI: 0). The 'IP' section includes 'DHCP Enable' (checkbox: checked), 'IP Address' (text: 192.168.0.128), 'Network Mask' (text: 255.255.255.0), 'Gateway' (text: 192.168.0.1), 'RIP v2 Enable' (checkbox), 'STP Enable' (checkbox), 'IGMPv2 Compatible Mode' (checkbox), 'Streamer VLAN Tag' (text: 0), 'Interlink Port' (text: 37682), and 'Actual Address' (text: 192.168.2.202). At the bottom, there are buttons for 'Apply', 'Refresh', 'Restore Defaults...', 'KeyFob Train...', 'Password...', 'ONVIF...', 'System...', and 'Set Clock...'.

6.2 AEON-MESH with AEON Encoder

These Streamer tab settings apply when the Encoder Config setting in the **Configuration>Unit** tab is configured as **AEON Single** or **AEON Quad**.

Property	Value	Description
AEON Remux	Stream	Set to Stream by default. This means that what is being encoded by the AEON will appear on the Streamer 1 output.
ASI Output	Checkbox	When set, the ASI output will contain the same content sent over Streamer 1.

6.3 AEON-MESH with SDR Dual Encoder

These settings apply when the Encoder Config setting in the **Configuration>Unit** tab is configured as **SDR Dual**.

6.3.1 Streamer 1

The screenshot shows the configuration page for 'AEON Mesh IP Radio' (9-10-AEONTX). The 'Configuration' tab is active, and 'Streamer 1' is selected. In the 'Mux' section, 'AEON Remux' is set to 'Off' and 'ASI Output' is an unchecked checkbox. In the 'Streamer' section, 'Streaming Mode' is 'Off', 'Base Address' is '236.254.202.108', and 'Base Port' is '10000'.

Property	Value	Description
AEON Remux	Off	Set to Off by default.
ASI Output	Checkbox	When set, the ASI output will contain the same content sent over Streamer 1.

6.3.2 Streamer 2

The screenshot shows the configuration page for 'AEON Mesh IP Radio' (9-10-AEONTX). The 'Configuration' tab is active, and 'Streamer 2' is selected. In the 'Mux' section, 'ASI Remux' is set to 'Stream'. In the 'Streamer' section, 'Streaming Mode' is 'Off', 'Base Address' is '236.254.202.111', and 'Base Port' is '20000'.

Property	Value	Description
ASI Remux	Off Stream	When set to Stream, this means that the remuxed ASI input will appear on the stream 2 output.

6.3.3 Record Enable

When Record Enable is set, the video will be recorded to the built in SD card. Recordings can be downloaded using the Domo Video Download Tool available on WatchDox, see *Section 11.1*.

To playback to a media player without downloading, set the Streaming Mode to **RTSP** and use the format:

rtsp://<ip_address>/play1.sdp (Streamer 1)

rtsp://<ip_address>/play2.sdp (Streamer 2)

6.3.4 Encoder

The screenshot shows the 'Encoder' configuration page in the AEON Mesh IP Radio interface. The 'Video Source' dropdown is highlighted with an orange box and set to 'SDI (ASI IN)'. Other visible settings include Video Format (Automatic), OSD Position (Off), OSD Type (Date Time), Bitrate Ratio (100%), and Advanced Mode (Off). The Motion Triggers section has Event Mode (Off), Event Action (None), Event Duration (0 seconds), and Event Threshold (0). The Event Mask section features a slider and 'Set All' and 'Clear All' buttons.

Property	Value	Description
Video Source	Off SDI (ASI IN) MJPEG 1 (USB)	Select the video input source. The physical port on the AEON Transmitter is indicated in brackets. Note: SDI input will only work when ASI IN is not being used to Remux.

7. AEON Transmitter LCD Display Operation

7.1 Overview

When in deployment, the AEON Transmitter may be controlled and monitored via the LCD display.

The LCD display will go into sleep mode after approximately one minute, to wake the LCD simply press or move the control knob in any direction.

When the LCD wakes up, the status view will be displayed.



7.2 Icons and Controls

The LCD display is controlled by the navigation knob on the top panel. The LCD display has some icons that let you know which knob movements are active.

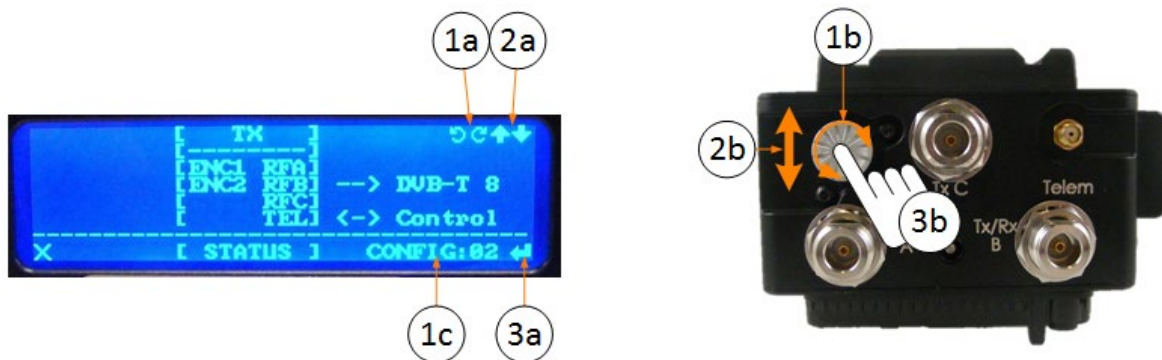

Item	Description
1a/1b	The rotation icons (1a) indicate that the knob rotation (1b) is active. When in the status view, rotation will change the config selection (1c).
2a/2b	The arrow icons (2a) indicate that the knob up/down movement (2b) is active. When in the status view, knob up/down will change the status pages.

Item	Description
3a/3b	The enter icon (3a) indicates that the knob press (3b) is active. When in the status view, press the knob to enter the config selection.

7.3 Navigating the Menu

From the status page, move the navigation knob **left** or **right**, to view the menu list, see below.

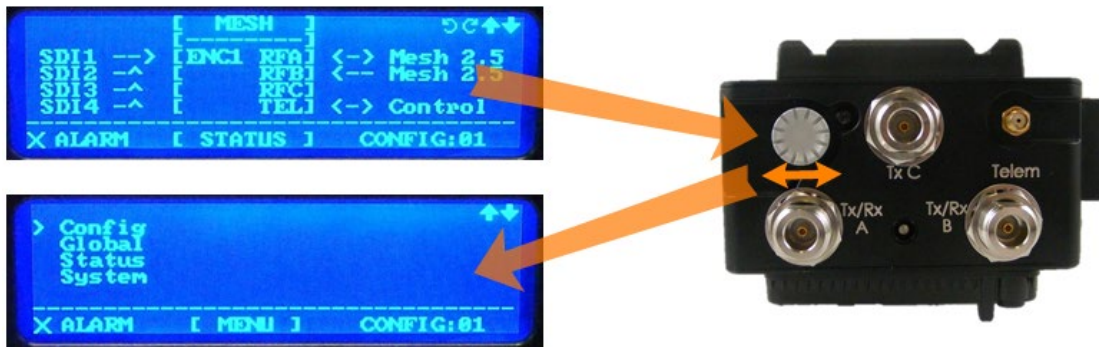

From this page, the menu structure can be navigated to a higher or lower level by moving the knob **left** or **right**.

Note: Always pay attention to the icons that are displayed to inform you of what knob actions are available.

When you navigate to a parameter that you wish to edit, you will find that knob **up/down** and **rotation** will both change the selection. When the desired selection has been made, use the knob **press** to save the value.



8. AEON Decoder Operation

8.1 Introduction

AEON Decoders are controlled from the front panel OLED display.

See *Section 3.3* for hardware connectivity.

8.2 OLED Display

8.2.1 Boot Up

After initialisation on boot up, the status page will be displayed. The status page displays current settings and video input information.



8.2.2 The Left Button

Push the left button to enter the display menu.

From the top menu level, the left button is inactive, but from lower menu levels the left button operates as an escape to the previous display.



8.2.3 The Right Button

The right button will navigate the menu list up and down and push to select.

When a parameter has been selected for edit, the right button can be used again to change the value by moving up/down or left/right to change the location of the cursor when editing a string value.

Press to save the setting.



8.3 Menus

The OLED display shows status information and allows the user to make some necessary configuration and unit settings.

Status Menu

The status menu provides status information relating to the configurations.

Configuration Menu

The configuration menu consists of sub-menus, each sub-menu allows editing of parameters:

- Video
- Audio
- Service
- IP Dec

Unit Menu

The unit menu allows editing of global unit settings, for example IP parameters. This is followed by unit level status information.

A unit restore defaults can be performed from the unit menu.

8.4 Software Upgrades

If you have an upgrade file which needs to be uploaded to the AEON Decoder, you will need to save it to a convenient location on your PC's file system.

Note: The file name will contain the version, check the **Unit** parameters on the OLED display to confirm the upgrade file is for a newer software version.

This upgrade takes 10 minutes, do not upgrade unless necessary.

Open a web browser and enter the IP address of the unit. The IP address can be found in the Status parameters on the OLED display.

Go to the upgrade page.

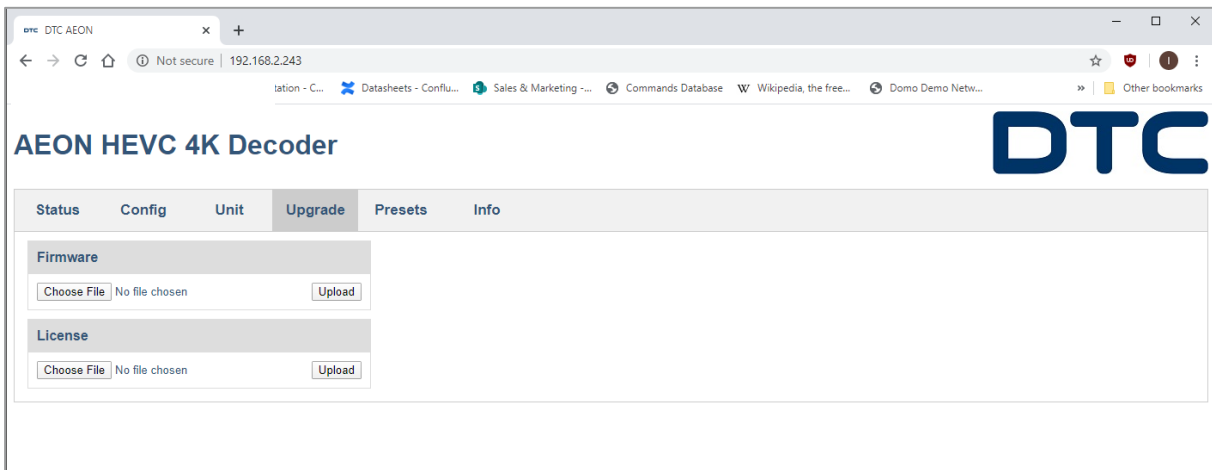

Click **Choose File** and browse to the saved upgrade file, select **Open** and click **Upload** on the web browser.

The web browser page will change from downloading code to an updating page. The power to the decoder **must not** be removed at any stage during the update.

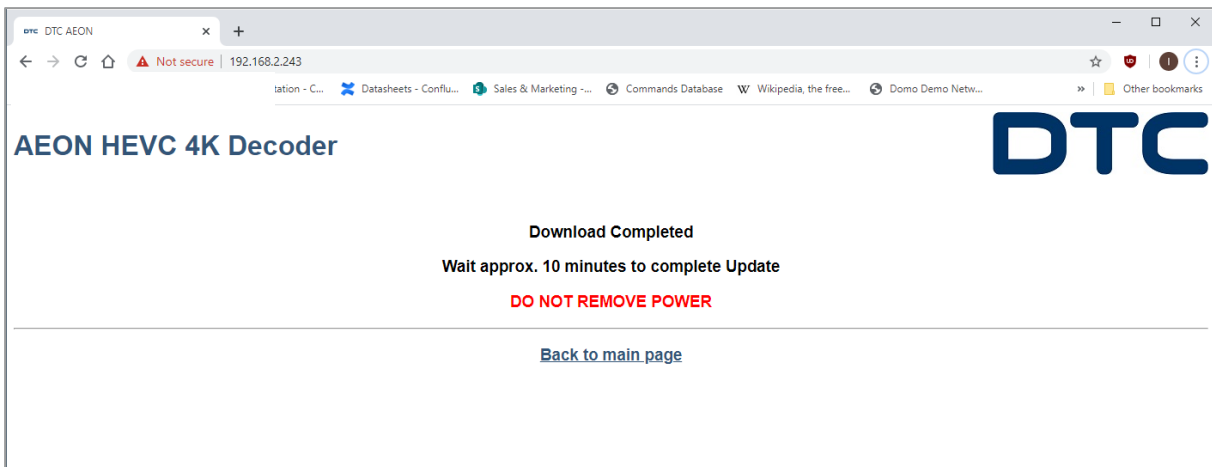

Simultaneously, the Decoder OLED display will show:



At the end of the upgrade, the Decoder OLED display will return to the status screen.

Note: The web browser will still display the update page which can now be closed.

At this point the unit must be power cycled to complete the process. The unit will check for further updates.

When the unit has rebooted, if the Decoder has detected that the controller firmware needs to updated, press the Decoder right button to enter or the left button to skip the update.



If you have pressed enter, the unit will upgrade and reboot, this may take a further few minutes. When complete, check the Status page for the updated software version.

9. Example Applications

9.1 Single AEON 4K HEVC System

9.1.1 Setup

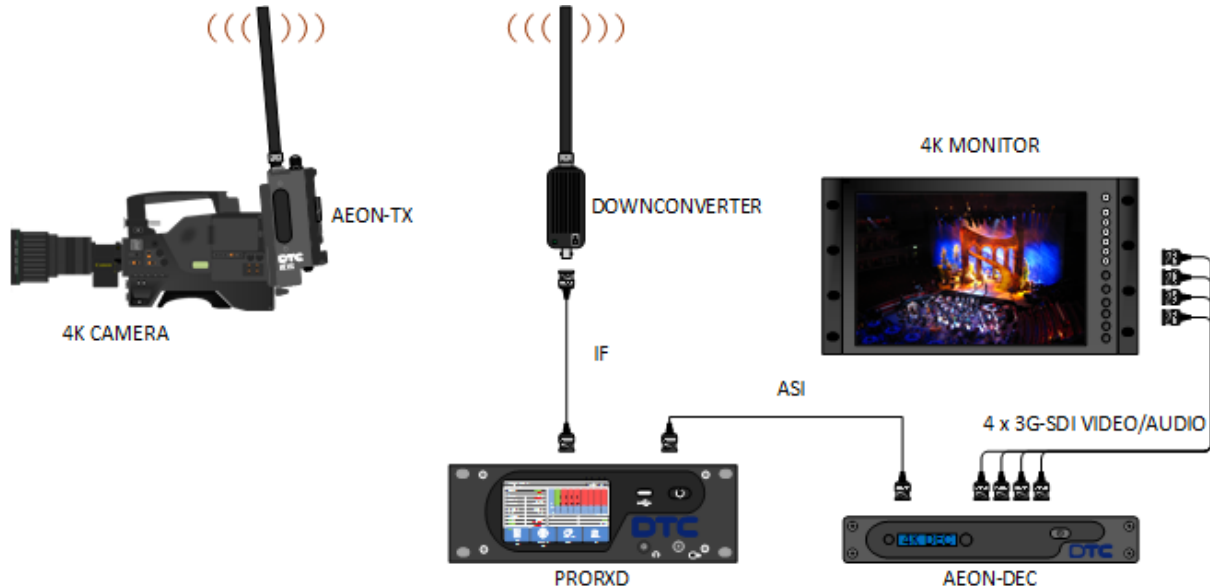

Figure 9-1 4K HEVC Video

Figure 9-1 is an example setup for an AEON Transmitter fitted to a 4K video camera. The COFDM transmission is received by a PRORXD and the ASI output is passed to the AEON Decoder. The decoded 4K video is output as 4 x 3G-SDI video to a monitor for viewing.

The PRORXD will need to be setup in accordance with the *PRORXD Broadcast Receiver User Guide*.

9.1.2 AEON-TX Configuration

There are some basic configurations that will have to be made to ensure a successful transmission.

Note: If changes are needed, ensure that the **Apply** button is clicked to save the changes.

On the **Global** tab ensure that the Application is set to **SOL-TX**.

AEON Transmitter
DTC

Unit Status
Configuration
Engineering

Global
1
2
3
4
5
6
7
8
9
10
11
12
13
14
15
16

Main
IP

Unit Name: AEONTX

Application: SOL-TX

Auxiliary Address: 1

Time Zone: GB - Europe/London

WiFi Country Code: GB

DHCP Enable:

IP Address: 192.168.0.128

Network Mask: 255.255.255.0

Gateway: 192.168.0.1

Actual Address: 192.168.2.202

On the **Encoder** tab set the video input encoding configurations. The Video Format and Video Rate **must** be matched by the **AEON Decoder**.

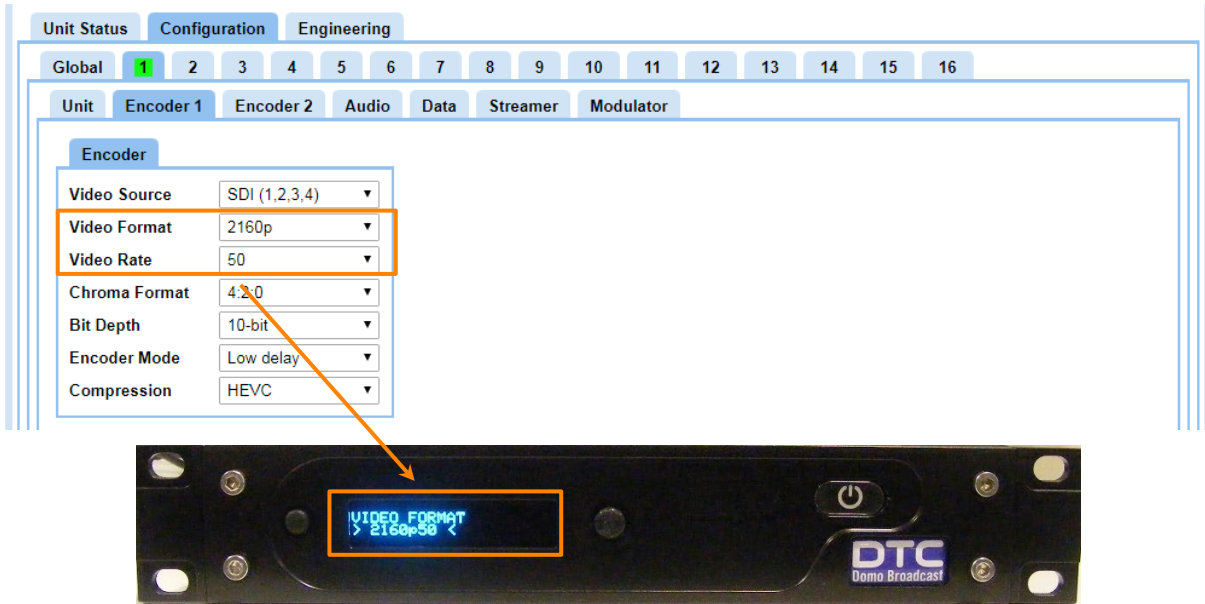

On the **Audio** tab set up the audio input configurations, if applicable.

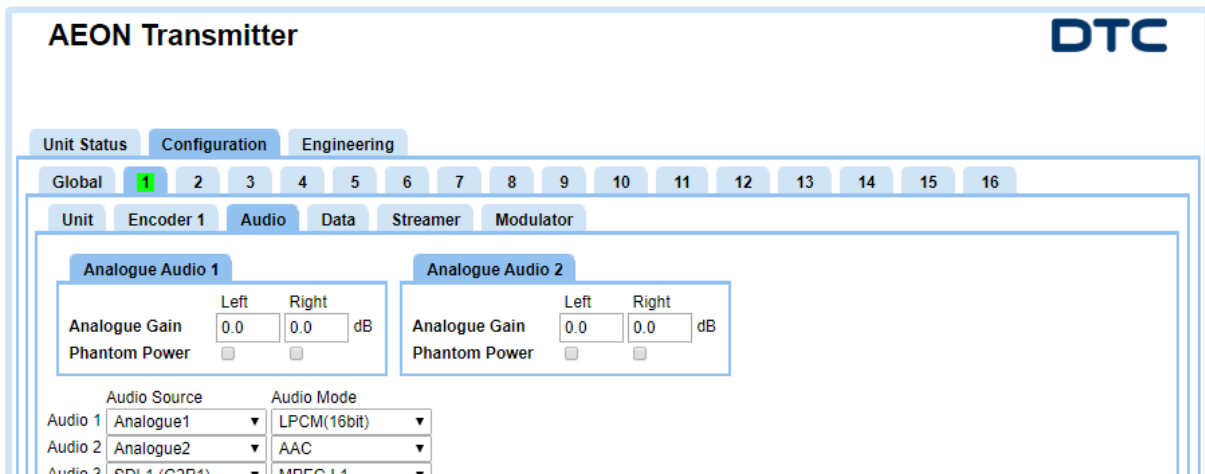

Ensure the **AEON Decoder** PIDs match the settings in the **Streamer** tab.

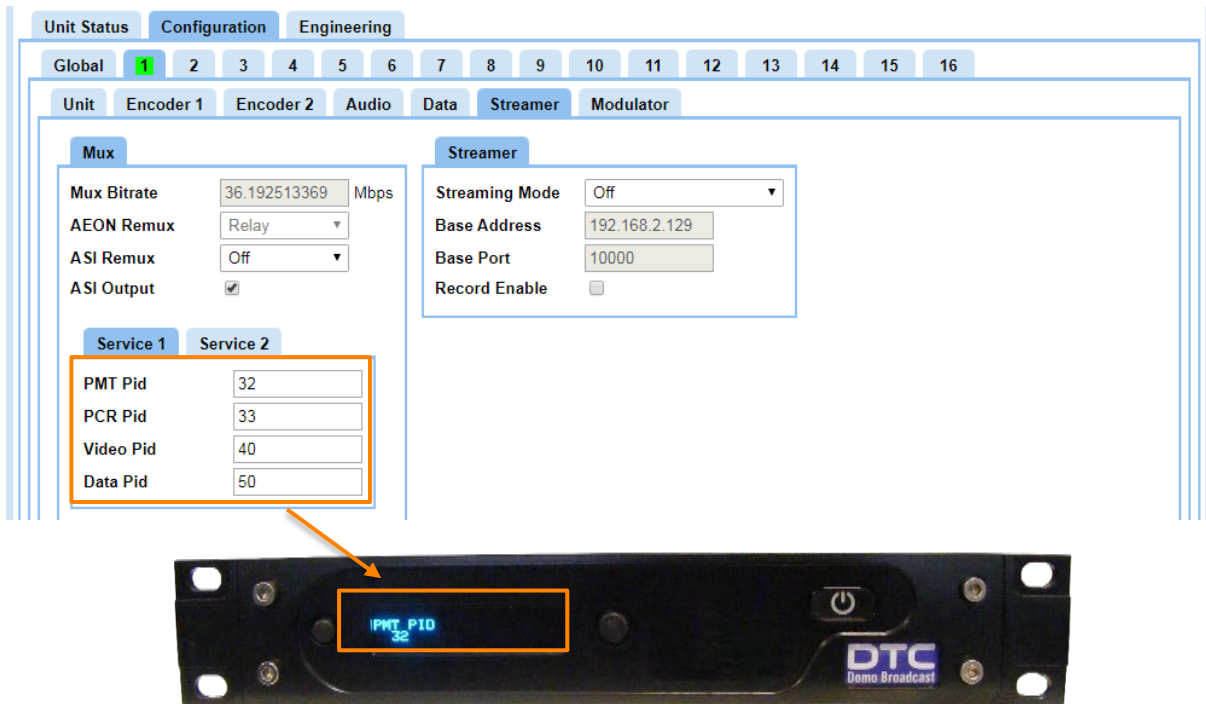

On the **Modulator** tab set up the modulation parameters, ensuring the correct **Modulation Mode**, **Frequency** and **Bandwidth** requirements for the system. These settings must be matched at the PRORXD receiver.

Set the **Modulation On** checkbox to turn the RF power on.

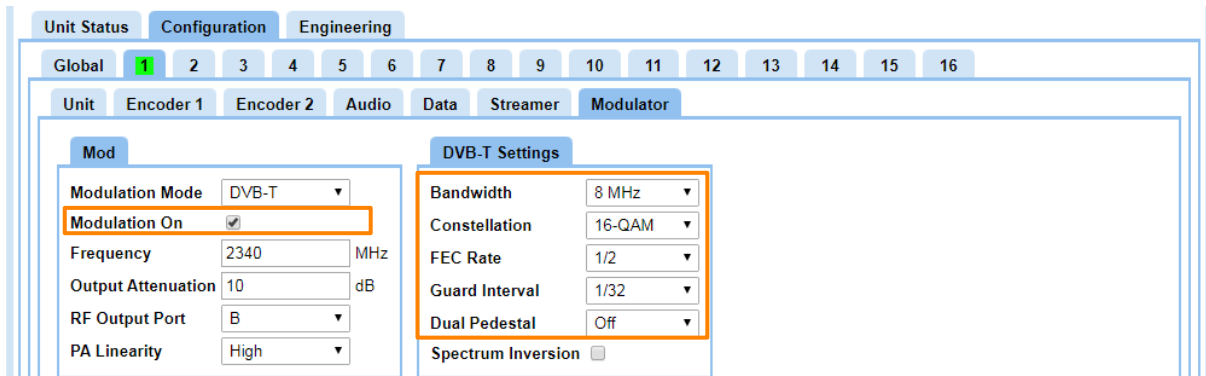

Recommended **DVB-T Settings** for optimum video:

- **HD 1080p50/59** – 16-QAM, FEC 1/2
- **HD 1080p50/59 with LPCM audio** – 16-QAM, FEC 2/3
- **Ultra HD 2160p50/59** – 16-QAM, FEC 1/2 or 2/3, Dual Pedestal enabled

The PRORXD Receiver should lock to the transmission and the demodulated ASI output passed to the AEON Decoder. The Decoder OLED display should show **ASI: Lock** and the 4 x 3G-SDI output is available at the Decoder for onward process.

9.2 MESH Application

9.2.1 Setup

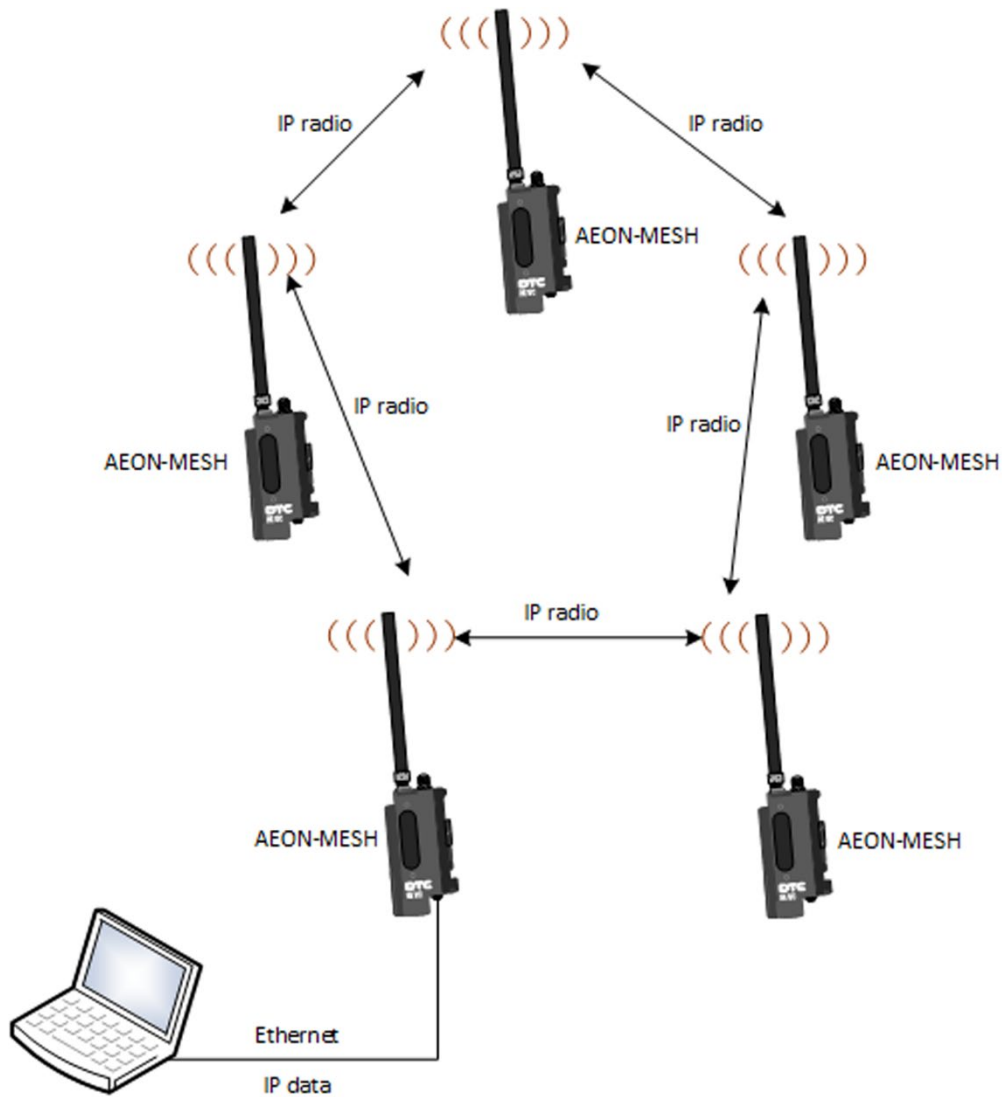

Figure 9-2 IP Mesh Radio

Figure 9-2 is an example setup of AEON Transmitters configured in an IP Mesh network. The network is a fluid, self-healing Mesh of up to 16 nodes on a single transmit frequency. The IP data can be passed onwards to a LAN or monitored on a laptop or PC.

For full details of Mesh operation, refer to DTC document *NETNode Phase 5 Software Guide* which has instructions which are compatible with the AEON-MESH.

9.2.2 AEON-MESH Configuration

There are some basic configurations that will have to be checked and set as appropriate to ensure a successful transmission.

Note: If changes are needed, ensure that the **Apply** button is clicked to save the changes.

On the **Global** tab ensure that the Application is set to **MESH** and configure the **IP settings** for the network.

The screenshot shows the 'AEON Transmitter' configuration interface. The 'Global' tab is selected, and the 'Main' sub-tab is active. The 'Application' dropdown menu is set to 'MESH'. The 'IP' sub-tab is also active, showing the following settings:

Unit Name	AEONTX	DHCP Enable	<input checked="" type="checkbox"/>
Application	MESH	IP Address	192.168.0.128
Auxiliary Address	1	Network Mask	255.255.255.0
Time Zone	--	Gateway	192.168.0.1
WiFi Country Code	00	Actual Address	10.183.2.79

On the **Mesh** tab set up the modulation parameters, ensuring the correct **Frequency** and **Channel Bandwidth** requirements for the system.

The **Mesh ID** should match for all Nodes in a Mesh network but the **Node ID** must be unique from 0 to 16.

Set the Transmitter **Enable** checkbox to turn the RF power on.

The screenshot shows the 'AEON Transmitter' configuration interface with the 'Mesh' tab selected. The 'Transmitter' sub-tab is active, showing the following settings:

Enable	<input checked="" type="checkbox"/>	Mesh ID	0
Frequency*	2340 MHz	Node ID	0
Channel Bandwidth*	2.5 MHz	Operating Range*	50km
Output Attenuation	0 dB		
RF Output Port	A		
PA Linearity	High		
Split Freq Mode	Disable		

Some consideration will need to be made to the **Unit** tab Operating Mode settings when transmitting 4K quality video as it will be necessary to put the unit into **MIMO Mesh** mode in order achieve the data requirements.

The screenshot shows the 'AEON Transmitter' configuration interface with the 'Unit' tab selected. The 'Misc' sub-tab is active, showing the following settings:

Encoder Config	AEON Single	RS485	
Operating Mode	MIMO Mesh	Data Mode	Off
GPS Source	Off	Baud Rate	19200
GPS Prefix	\$GP	Parity	None

The AEON Mesh network can be viewed in the **Unit Status>Mesh>Overview** page.

AEON Mesh IP Radio

41 - 2 - Hamet_2

Unit Status
Configuration
Engineering

Mesh 1
Overview
Streamer 1
Streamer 2
SDI / SFP

Overview
Spectra
Maps

Node ID	0	1	2	7	8	9	10	11	12	13	14
Unit Name	Hamet_1	Hamet_3	Hamet_2	HH_3	Loose	HH_6	HH_2	HH_1	HH_5	HH_4	SMOKEY
IP Address	192.168.2.139	192.168.2.249	192.168.2.194	192.168.2.212	192.168.2.237	192.168.2.229	192.168.2.240	192.168.2.189	192.168.2.157	192.168.2.242	192.168.2.1
Battery Voltage	12.5 V	12.5 V	12.5 V	12.0 V	13.2 V	12.8 V	12.0 V	11.9 V	12.0 V	12.0 V	12.2 V
FPGA Temp	51.0 °C	54.0 °C	50.0 °C	38.0 °C	70.0 °C	45.0 °C	39.0 °C	38.0 °C	41.0 °C	39.0 °C	46.0 °C
Occupancy											
Node TX Retries	-	-	-	-	-	-	-	-	-	-	-

Show Details

Signal Quality

Rx \ Tx	0	1	2	7	8	9	10	11	12	13	14
0		26.9	26.3	24.0	20.8	19.6	21.8	20.6	23.6	20.4	23.9
1	26.8		25.4	23.0	20.6	21.3	23.3	20.8	20.7	22.4	23.6
2	28.4	27.5		24.6	22.4	24.9	24.1	22.9	24.9	23.5	24.4
7	25.2	24.3	23.9		21.4	23.9	21.4	23.1	20.6	21.8	20.0
8	24.6	24.6	24.7	24.3		19.3	22.8	24.1	25.1	22.3	14.6
9	23.1	25.1	24.8	25.0	21.2		24.5	24.2	25.0	24.0	22.3
10	24.4	23.5	23.6	22.9	22.1	24.6		18.8	11.0	21.9	20.4
11	21.6	21.7	22.8	23.3	22.3	25.5	22.4		22.9	18.1	20.9
12	25.4	20.2	24.0	15.4	22.6	23.6	9.6	23.4		23.3	22.4
13	24.9	24.6	23.9	22.4	22.0	24.8	22.3	18.4	24.8		23.0
14	25.3	24.1	23.9	25.5	22.8	26.6	25.9	25.1	26.2	24.6	

10. Appendix A – Reference Material

10.1 How to Configure a PC IP Address

The following guide will tell you how to configure your PC or laptop IP address so that it matches the IP address range of the unit you are connected to. This is important because if they don't match, you will not be able to communicate with your device.

The IP address range given in this example is a good one to use if you are unsure.

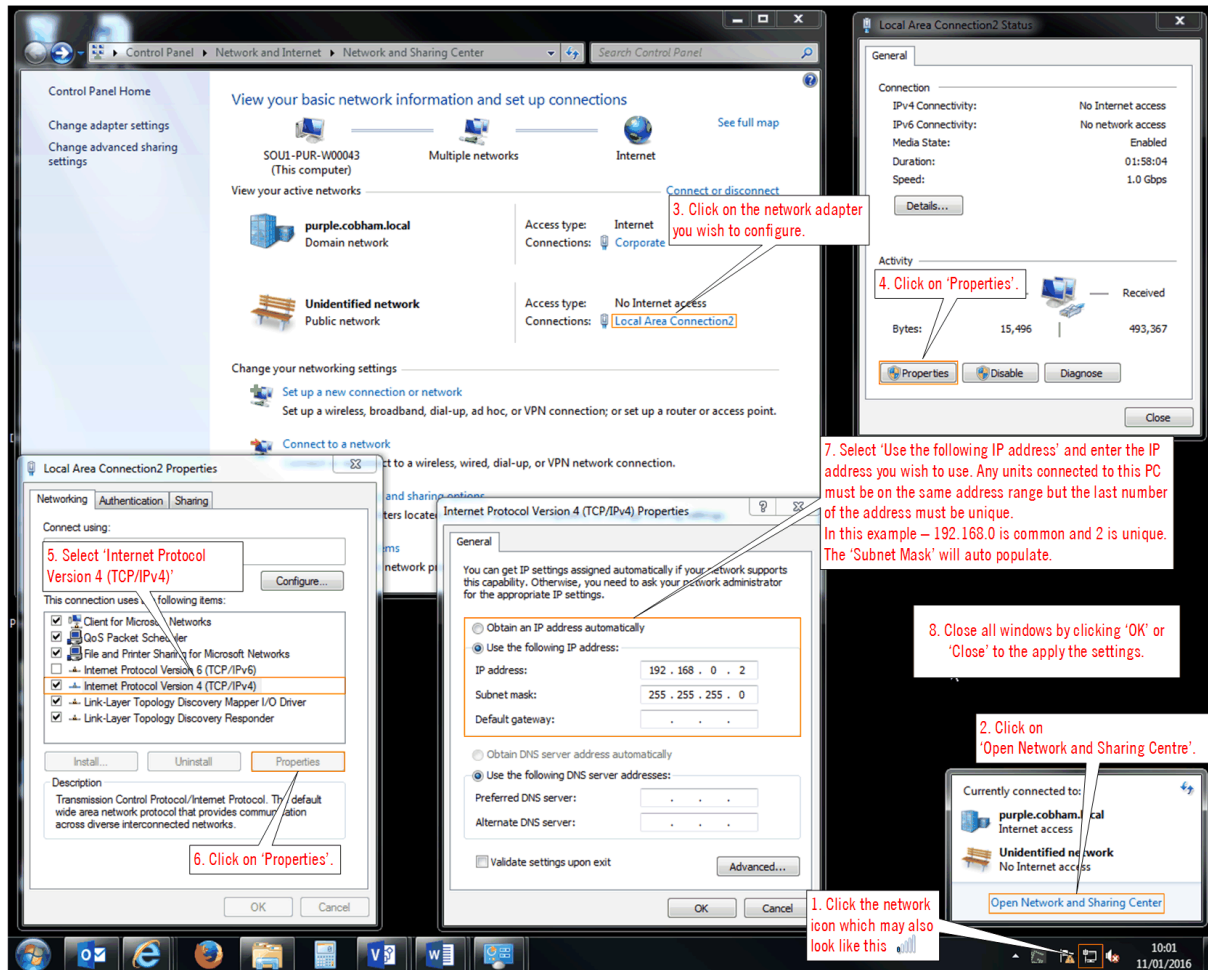

Figure 10-1 How to configure a PC IP address

10.2 AEON Transmitter Pinouts

10.2.1 CAMERA

Circular Hirose 10-way – HR10A-10R-10P (73)

Pin	Function
1	RS422 TX (H)
2	RS422 TX (C)
3	RS422 RX (H)
4	RS422 RX (C)
5	GND
6	RS232 TX
7	RS232 RX
8	N/C
9	N/C
10	GND

10.2.2 Tally

OB Lemo 5-way – EGG.OB.305.CLL

Pin	Function
1	GND
2	VBATT Out
3	RED
4	GREEN
5	N/C

10.2.3 DATA

OB Lemo 4-way – EEA.OB.304.CLL

Pin	Function
1	DATA_TX_RS232
2	DATA_RX_RS232
3	PA_TDD

Pin	Function
4	GND

10.2.4 Audio 1 and 2

OB Lemo 5-way – EEA.OB.305.CLL

Pin	Function
1	AUD_IN_L+
2	AUD_IN_L-
3	GND
4	AUD_IN_R+
5	AUD_IN_R-

10.2.5 Power

OB Lemo 4-way – EEG.OB.304.CLL

Pin	Function
1	VIN
2	VIN
3	GND
4	GND

10.3 AEON Decoder Pinouts

10.3.1 RS-232

Pin	Function
1	N/C
2	RS232 TX
3	RS232 RX
4	N/C
5	GND
6	N/C
7	N/C
8	N/C
9	N/C

10.3.2 Audio Inputs

OB Lemo 5-way – EEA.0B.305.GLL

Pin	Function
1	AUD_IN_L+
2	AUD_IN_L-
3	GND
4	AUD_IN_R+
5	AUD_IN_R-

10.3.3 Audio Outputs

OB Lemo 5-way – EEA.0B.305.GLL

Pin	Function
1	AUD_OUT_L+
2	AUD_OUT_L-
3	GND
4	AUD_OUT_R+
5	AUD_OUT_R-

11. Appendix B – After Sales Support

11.1 Documentation and Software

It is DTC's practise to make the majority of our latest user guides and software available to customers online, by using our WatchDox facility. To access this site, please contact your Account Manager or send a request to solent.support@domotactical.com.

You will be sent a link where you can log in and create your own password followed by a confirmation email. Once you have done this, you can then log in to your account.

11.2 Contact Technical Support

The Technical Support team can be accessed by one of the following:

- **Post:** DTC – Solent, Fusion 2, 110 Parkway, Solent Business Park, Whiteley, Hampshire, PO15 7AB, England
- **Phone:** +44 1489 884 550. Office hours: 0900-1700 UK time excluding holidays
- **Email:** solent.support@domotactical.com (no restricted content)

11.3 Using the DTC RMA Service

If there is a problem and all troubleshooting steps have been unsuccessful, you may need to contact DTC for Return Material Authorisation (RMA) service.

11.3.1 Contact DTC

Please call our Technical Support Line on +44 (0) 1489 884550. If this has been done and the issue cannot be resolved, email solent.customerhub@domotactical.com to request an RMA form.

11.3.2 Complete and Return the RMA Form

Complete the RMA form with the following information and return to the customer hub:

- Name
- Address
- Unit serial number
- Date of purchase or the original invoice number
- Date of failure
- A detailed description of the problems you have encountered
- A list of the hardware/software configuration if applicable

Once the hub receive the complete form, we will then send an RMA number and shipping instructions.

11.3.3 Pack the Device

Note: Before packing, remove all personal non-DTC kit or media from the device.

Use the original shipping container and packing materials, if possible.

If the original packing materials are not available, wrap the equipment with soft material (e.g. PU/PE form) then put the wrapped equipment into a hard cardboard shipping box.

11.3.4 Put the RMA Number on the Box

Clearly mark the outside of the shipping box with the RMA number. If an RMA number is not present on the shipping box, receiving will be unable to identify it and it might be returned.

11.3.5 Send the Box to DTC

Send the box using your normal shipping process.

12. Appendix C – Safety and Maintenance

12.1 Cautions and Warnings

Note: The following guidelines may or may not be applicable to your product. However, we would ask that you read them to assess their relevance.

Area	Note
Enclosures	<p>Do not remove any factory installed screws or fastenings. Damage to the units may result and void any warranties.</p> <p>Only authorised, trained personnel should open the product. There are no functions that require the user to gain access to the interior of the product. There are no user serviceable parts inside.</p>
Maintenance	Other than cleaning, no scheduled maintenance is required to ensure proper function of the unit.
Environment	The equipment should not be used in hazardous or corrosive atmospheres. Users are reminded of the necessity of complying with restrictions regarding the use of radio devices in fuel depots, chemical plants and locations where explosives are stored and/or used.
Power supply	Ensure that the power supply arrangements are adequate to meet the stated requirements of each product. Observe all electrical safety precautions.
Electro static discharge precautions	ESD guidelines must be followed for this electrostatic sensitive device.
Lightning strike	There is a risk of lightning strike to antennas. The equipment should not be assembled in an area at the time of lightning activity. Antennas should be adequately protected from lightning strikes.
Working at height	Observe caution when locating the device at height, for example on a mast. Ensure the unit is well secured to prevent it falling and injuring personnel.
Risk of eye injury	Care should be taken to avoid eye contact with the antennas.
Cables	Connecting cables should not be positioned where they are likely to become damaged or where they may present a trip hazard.
Thermal control system	<p>Any powered device will always produce heat as a by-product of its operation. If you operate this device in an enclosed space you must ensure it has adequate airflow to keep it cool.</p> <p>Also, if worn close to the body, care must be taken to protect the operator from excessive temperatures.</p>
RF emission system	When using this device please ensure a distance of 20cm is maintained between your device and your body while the device is transmitting.

Area	Note
Aircraft safety	<p>Use of this equipment on board aircraft is strictly forbidden, unless confirmed as safe by the aircraft operator.</p> <p>Use of radio transmitter equipment in an aircraft can endanger navigation and other systems.</p>
Heat	<p>Precautions may need to be taken to avoid burns when operating the device in high ambient temperatures due to excessive heat from the unit metalwork.</p> <p>The device temperature should be monitored to prevent overheating beyond specified limits.</p>

12.2 Repairs and Alterations

Attempted repairs, alterations, improper installations or connections may invalidate the warranty. Please contact Technical Support if you suspect a faulty or defective component. See *Section 11.2*.

12.3 Caring for your Equipment

- Do not subject the unit to physical abuse, excessive shock or vibration
- Do not drop, jar or throw the unit
- Do not carry the unit by the antenna
- Avoid exposure to excessive moisture or liquids
- Do not submerge the unit unless it is designed to be submersible
- Do not expose the unit to corrosives, solvents, cleaners or mineral spirits
- Avoid exposure to excessive cold and heat
- Avoid prolonged exposure to direct sunlight
- Do not place or leave units on surfaces that are unstable
- Only use accessories intended for the specific make and model of your unit, especially batteries, chargers and power adapters.

12.4 Charging

- Use approved batteries, chargers and adapters designed specifically for your make and model unit
- Do not attempt to charge a wet unit or battery pack
- Do not charge the unit or battery pack near anything flammable
- Stabilize the battery pack to room temperature (22°C) before charging
- Do not charge units and/or battery packs on wet or unstable surfaces
- Do not leave units and/or batteries in chargers for excessive periods

12.5 Working with Lithium Batteries

- Charge only with the approved charging cable
- Batteries are to be used only for the specified purpose. Incorrect use will invalidate the warranty and may make the battery become dangerous.
- Charge in a clean, dry environment ideally at 10°C (0 to 45°C is permissible).
- Do not store or operate in direct sunlight for extended periods. Battery can be damaged by over-heating, for example if placed on the rear parcel shelf of a motor vehicle.
- Store in a cool dry environment. Storage at elevated temperatures can cause permanent loss of capacity.
- For short term storage (less than six months), store in a fully charged state.
- For extended periods of storage (more than one year), charge before storage and recharge every six to nine months.
- Always fully recharge the battery after any storage period greater than one month before use.
- Do not store the battery with the charge depleted as this can cause failure of the battery and invalidate warranty.
- Do not short circuit
- Do not immerse in water
- Do not incinerate. Cells are likely to explode if placed in a fire.
- Dispose of batteries in accordance with the regulations in place for the country of use. Batteries are normally considered separate waste and should not be allowed to enter the normal waste stream. Either return to the seller, or deliver to an approved re-cycling facility.

12.6 Cleaning

- Turn off the unit and remove batteries (if applicable) before maintenance
- Use a clean, soft, damp cloth to clean the unit. A microfiber cloth is recommended.
- Do not use alcohol or cleaning solutions to clean the unit
- Do not immerse the unit in water to clean it
- If the unit becomes wet, immediately dry it with a microfiber or other lint-free cloth

12.7 Storage

- Turn off the unit and remove batteries before storage
- Store units and battery packs in a cool, dry area at room temperature (22°C)
- Do not store units and/or batteries in active chargers

13. Appendix D – Glossary

A	Definition
AES	Advanced Encryption Standard. Originally published as Rijndael, this specification has been adopted by the U.S. government. Each AES cipher has a 128-bit block size, with key sizes of 128 and 256 bits, respectively.
ASI	Asynchronous Serial Interface is a streaming data interface which often carries an MPEG Transport Stream. An ASI signal can carry one or multiple SD, HD or audio programs that are already compressed, not like an uncompressed SD-SDI (270Mbps) or HD-SDI (1.45Gbs). An ASI signal can carry varying amounts of data but is always padded to run at a fixed line rate of 270 Mb/s.
Antenna Bandwidth	The frequency range over which a given antenna will accept signals.
Antenna Gain	Antenna gain is a measure of how well an antenna converts power into radio waves or radio waves into power, depending on whether it is fitted to a transmitter or receiver device. Antenna gain is expressed in dB (decibels).

B	Definition
Bandwidth	The width of a band of frequencies used for a particular purpose.

C	Definition
COFDM	Coded Orthogonal Frequency Division Multiplexing is a frequency-division multiplexing (FDM) scheme utilized as a digital multi-carrier modulation method. A large number of closely-spaced orthogonal sub-carriers are used to carry data.

D	Definition
Decibel (dB)	The standard unit used to express transmission gain or loss and relative power levels.
Decoder	A processor in a receiver which converts compressed digital video or audio data to a format suitable for monitoring.
Demodulate	To recover the information originally impressed on the radio wave.
Downconverter	A device which converts microwave frequencies to UHF frequencies for use in DTC receivers.

E	Definition
Elementary Stream (ES)	These streams contain only one MPEG video or audio channel. Elementary streams are required if you intend to use Milestone or any player that cannot operate with transport streams.
Encoder	A processor in a transmitter which converts video or audio to compressed digital signals.

F	Definition
FEC	Forward Error Correction is a system of error control for data transmission, whereby the sender adds redundant data to its messages. This allows the receiver to detect and correct errors without the need to ask the sender for additional data.
FPGA	A Field-Programmable Gate Array is an integrated circuit which can be programmed to perform complex logic functions. The software can be upgraded in the field, hence, field-programmable.

G	Definition
Gain	An increase in signal strength, typically by an amplifier.
GUI	A Graphical User Interface allows users to interact with an electronic device.

I	Definition
IP address	An Internet Protocol address is a unique numeric ID for a device within a network.

L	Definition
LOS	Line-of-sight propagation refers to electromagnetic radiation which travels in a direct path from transmitter to receiver.

M	Definition
MPEG	Moving Pictures Experts Group is an organisation that sets the standards for audio and video compression and transmission.
Modulation	To change the output of a transmitter in amplitude, phase or frequency in accordance with the information to be transmitted. Data is superimposed on a carrier current or wave by means of a process called modulation.

M	Definition
Multicast	Multicasting is sending data from a sender to multiple receivers where each receiver signals that they want to receive the data.

N	Definition
NLOS	Non-line-of-sight propagation refers to electromagnetic radiation which travels in a path which is obstructed by physical objects.
NTSC	National Television Systems Committee is the analogue television system used mainly, but not exclusively, in the Americas.
Noise	Unwanted disturbance in an electrical signal.

O	Definition
Omnidirectional antenna	An antenna whose radiation pattern shows equal radiation in all horizontal directions.

P	Definition
PAL	Phase Alternate Line is the analogue television system used mainly, but not exclusively, throughout the world (see NTSC).
PTZ	Pan-tilt-zoom is a common way of referring to controllable cameras.

Q	Definition
QAM	Quadrature Amplitude Modulation. DTC products commonly use either the 16 state (16-QAM) or 64 state (64-QAM) modulation schemes
QPSK	Quadrature Phase Shift Keying digital modulation scheme.

R	Definition
RTSP	Real Time Streaming Protocol (RTSP) is a network control protocol designed for the transfer of real-time media data The protocol is used for establishing and controlling media sessions between end points.

S	Definition
SDI	Serial Digital Interface (SDI) is a standard used for the transmission of uncompressed digital video signals, often including embedded audio.
SNR	Signal to Noise Ratio is an electrical engineering measurement defined as the ratio of wanted signal power to the corrupting noise power. The higher the ratio, the less obtrusive the background noise is.
Streaming	Streaming is the transmission of digital media over an IP network.

T	Definition
Transport Stream (TS)	A standard digital container format for transmission and storage of audio, video, and Program and System Information Protocol (PSIP) data. Channels are multiplexed together, allowing the receiver to choose which to play back.

U	Definition
UDP	User Datagram Protocol (UDP) is a core of the Internet Protocol Suite. UDP does not employ reliability mechanisms, therefore, if the receiver does not get a packet, the sender will never know. However, UDP is very efficient when there is little chance of errors.
USB	Universal Serial Bus defines the cables, connectors and protocols used in electronic bus connections.
Unicast	Unicast is simply sending packets from one source to one destination.

V	Definition
Viterbi Decoder	A Viterbi decoder uses the Viterbi algorithm for decoding a bit stream that has been encoded using forward error correction based on a convolutional code.

W	Definition
Waveguide	A specially formed hollow metal tube, usually rectangular in shape in cross section, used to connect a high power amplifier to the antenna.